

## Characterization and Correction of Casting Defects

Timothy L. Donohue  
Dr. Helmut F. Frye, Ph.D.  
TechForm -  
*Advanced Casting Technology, L.L.C.*

Platinum casting defects are often very difficult to characterize due to the intrinsic complexity of the investment casting process. All defects will fall into one or more of the established seven categories of casting defects. The proper identification of a particular defect is the prerequisite to correcting and controlling the quality of platinum castings. It is contended that a system of defect identification should be based solely upon morphological criteria with no prior assumptions relating to the cause of the defect. The nature of a casting defect can only be determined by correctly categorizing the shape, appearance, loca-

tion and dimensions of the defect. The importance of a controlled and comprehensive defect analysis program is advanced. Once appropriately classified, the possible causes can be examined and the corrective action can be taken.

Investment casting has often been referred to as "a process that really knows how to keep a secret." Even in a controlled process, defects in the output can occur which defy rational explanation. The complexity of the process is the result of integrating the varied disciplines of physics, thermodynamics and chemistry. When these factors are combined with the problems associated with the high temperature alloys of the platinum family, the root cause of a casting defect can truly become a mystery.

Casting defects in a controlled process will generally fall into one of two categories. Defects can be *chronic*, i.e., long-standing, which require a remedy through a process change usually via designed experiments;

or, *sporadic*, which are sudden adverse changes in the normal capability of the process. Sporadic defects are probably the most troublesome for casters. In a controlled process defects do not just happen, they are caused. "If a defect occurs, measures must be adopted to eliminate its cause and prevent its repetition."<sup>1</sup> It is the purpose of this article to examine the characterization, analysis and correction of only sporadic platinum casting defects because, "the roads to diagnosis and remedy differ remarkably for sporadic

defects and chronic defects."<sup>2</sup>

## Defect Characterization

Two distinct journeys must be taken to correct sporadic defects. They are "the diagnostic journey from symptom to cause and the remedial journey from cause to remedy"<sup>3</sup> (see *Figure 1*). There is a temptation to attempt to diagnose a defect by the possible causes; but, an incorrect diagnosis of the root cause can lead to an incomplete or incorrect remedy of the problem. It is

important to correctly identify the defect symptoms prior to assigning the cause to the problem. False remedies not only fail to solve the problem, they can confuse the issues and make it more difficult to cure the defect.

In general, a casting defect is defined as an observable and un-

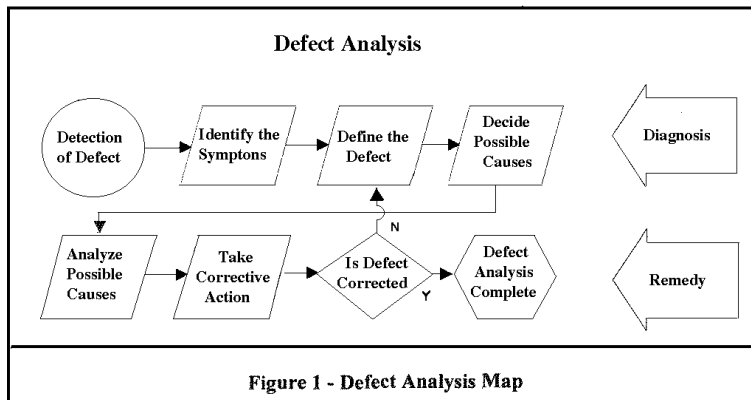

planned variation of a specification. The identity of a particular casting defect is based upon the specific shape, appearance, location and dimension or profile of the anomaly. The proper identification of a specific defect is the prerequisite to correcting and controlling the quality of castings. A problem solving approach that is characterized by the unique “morphology of the defects is more logical than one based upon the causes since it requires no prior assumptions to be made.”<sup>4</sup> The idea is to empirically observe the symptoms in order to classify and define the defect.

There are only seven categories of casting defects, which have been established.<sup>5</sup> These defects are:

- A. Metallic Projections
- B. Cavities
- C. Discontinuities
- D. Defective Surface
- E. Incomplete Casting
- F. Incorrect Dimensions or Shape
- G. Inclusions or Structural Anomalies

Very often in the jewelry industry, a defect will be referred to as “pitting” which can either be due to cavities, discontinuities or a defective surface. Since the cause and remedy of each category of defect will involve a distinct corrective action, it is apparent that “pitting” will need to be defined more specifically to resolve the problem. This is why the shape, appearance, location and dimension or profile of the defect is important to observe and record in order to classify the defect. The following will examine the seven categories of defects in greater detail as well as some of the possible causes as they relate to platinum casting.

#### *Joint Flash or Fins:*

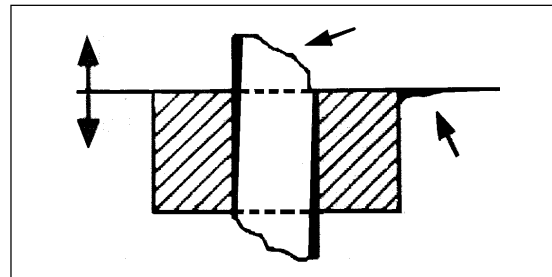

## Category A: Metallic Projections

These appear as projections of irregular thickness often with lacy edges. They are perpendicular to one of the faces of the casting surface. They occur along the joint or parting line of the mold or wherever two elements of the mold intersect.

*Possible Causes:* Flash could be left on in the wax pattern or joints in wax are angular.

### *Veining or Finning:*

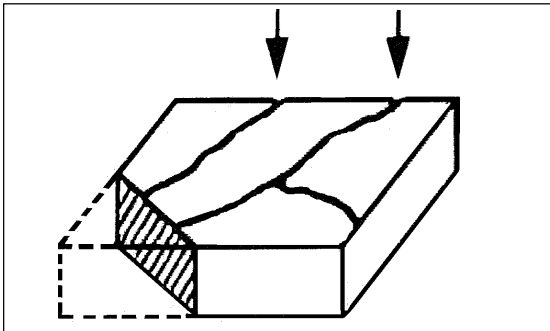

These are projections in the form of

veins that are generally perpendicular to the casting surface and occur either singularly or in networks. They are not situated along parting lines.

*Possible Causes:* Improperly dried mold, temperature too high in kiln or heating curve too rapid.

### *Cracked or Broken Mold:*

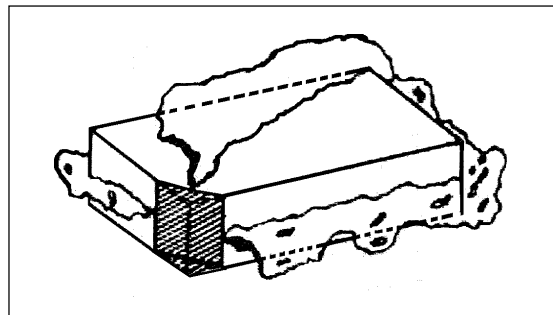

This is the formation of large thin fins in planes related to the position of the casting in the mold. Cracks will initiate at the surface of the mold cavity and extend through the zones of least resistance.

*Possible Causes:* Mold has been fractured:

1. During investment of the pattern.
2. At the time of dewaxing
3. During thermocycling
4. During casting, due to an inadequate strength of the investment

*Sweating or Dip Air.*

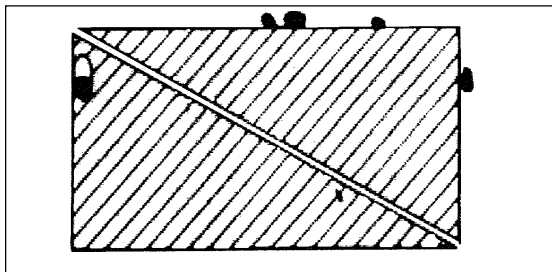

Smooth surface metallic projections that are nearly spherical in shape. This defect occurs most often in reentrant angles, blind holes and undercuts.

*Possible Causes:* Air bubbles lodged within the investment close to the pattern. The thin layer of ceramic next to the pattern is broken through during casting and the air

bubbles fill with metal.

**Category B:**  
Cavities

*Blowholes, Pinholes:*

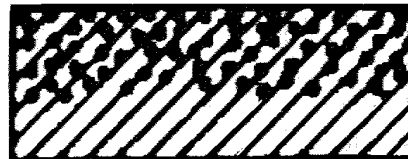
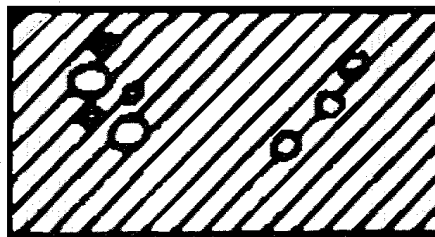

These are smooth walled, nearly spherical, cavities often not contacting the surface. Smaller cavities appear in groups while larger cavities appear most often in isolation. These defects can appear in all

regions of the casting.

*Possible Causes:* These are produced by gas entrapped in the metal during solidification and caused by:

1. Metallurgical origin (any gas content in the heat that is not dissolved, e.g., N<sub>2</sub> or H<sub>2</sub>).
2. Gas from mold materials (excess binders, additives or hydrocarbons from waxes).
3. Mechanical entrapment (due to insufficient mold permeability or turbulence in the gating system).

This phenomenon can also be observed if the holes were originally in the wax and went to investing without correction.

### *Dispersed Shrinkage:*

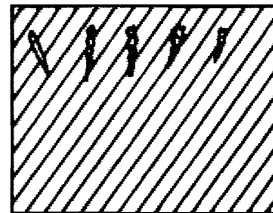

Narrow cavities resembling tears or fissures, generally perpendicular to the surface of the casting. Their depth may be as great as 2 cm. The internal surface of the cavity is dendritic.

*Possible Causes:* Improper gating of thick areas of the pattern or the incorrect casting parameters to allow proper solidification.

### Open or External Shrinkage:

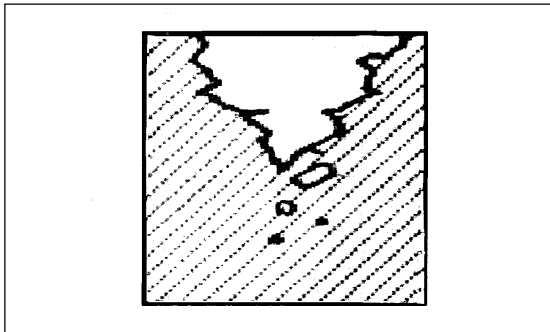

This is a shrinkage cavity that extends to the exterior surface of a casting. This generally occurs in heavy sections with a funnel shaped and sometimes elongated pattern.

*Possible Causes:* Shrink is always caused by the volume contraction of metal during solidification. External shrink will appear when molds are improperly gated far from the heavy sections.

### Internal or Blind Shrinkage:

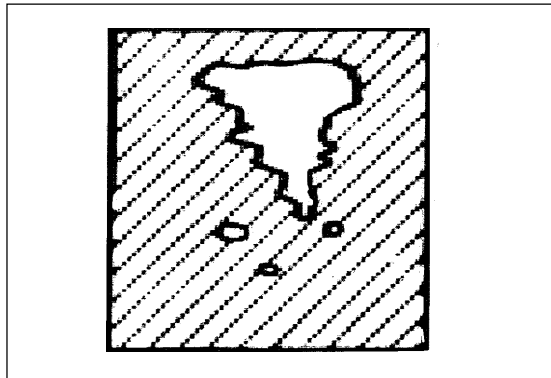

Shrinkage cavity normally found in heavy sections of a casting; but, the funnel shape defect does not extend to the surface. The defect generally is located toward the upper section of the casting or at the intersection of casting walls.

*Possible Causes:* Metal contraction during solidification-improper gating design.

### Corner or Fillet Shrinkage:

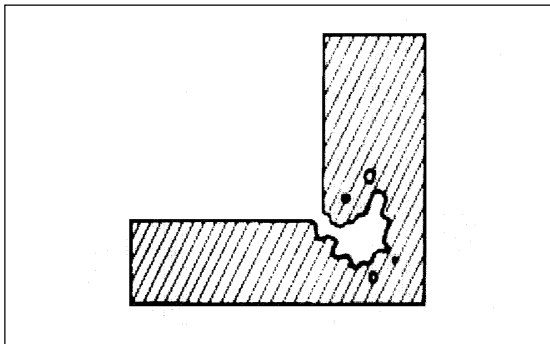

A cavity that emerges to the surface in reentrant angles of the pattern, at gates or at isolated surfaces that are characterized by slow solidification. The walls of the cavity are most often rough and dendritic.

*Possible Causes:* Primarily due to “hot spots” or heat affected zones. Improper gating at mold intersection; and the possible intervention of atmospheric or mold gas pressure.

### Centerline or Axial Shrinkage:

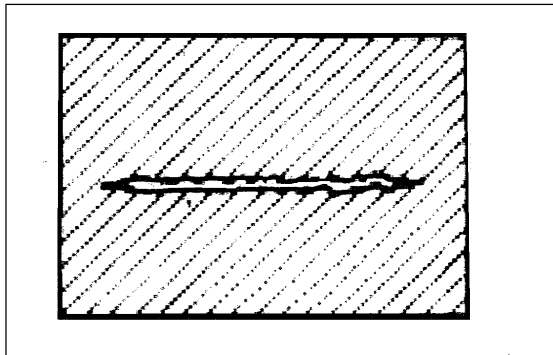

A cavity or porous region along the centerline of casting sections that is plate-like or worm-like in shape.

*Possible Causes:* Improper gating or casting parameters (flask too cold).

### *Macroshrinkage, Microshrinkage or Shrinkage Porosity:*

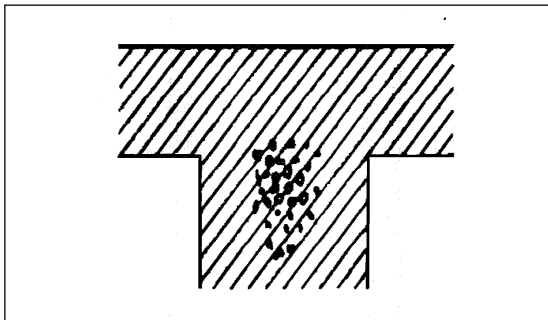

This defect has a spongy appearance, sometimes dendritic or in the form of small superimposed cavities. It is generally localized in the last section to freeze off during solidification. It is most often found in alloys with a wider liquidus-solidus range.

*Possible Causes:* Improper gating or casting parameters.

### **Category C:** Discontinuities

#### *Hot Cracking:*

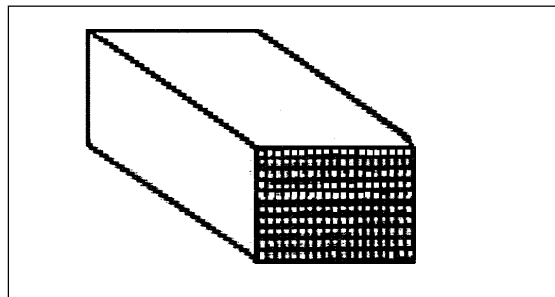

A crack, often scarcely visible because the casting has not separated into fragments. The design of the casting is such that the crack would not be expected to result from the solidification forces during cooling.

*Possible Causes:* Damage or trauma to casting while still hot; normally due to rough handling.

### Hot Tearing:

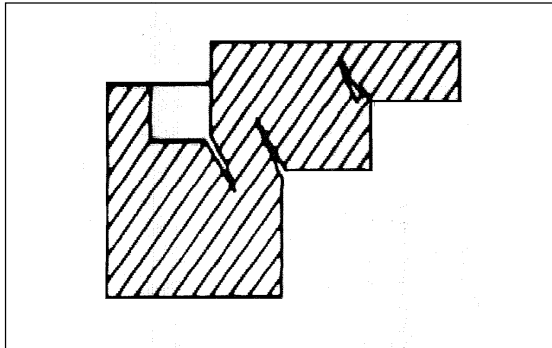

More or less deep intercrystalline fissures of irregular outline characterize this defect. The cracks often show a fine dendritic structure. The defect most often appears in the last sections of the casting to solidify where sharp angles or wide variations of mass are present.

*Possible Causes:* Hindered contraction of metal due to faulty gating design or a complex feature.

### Quench Cracking:

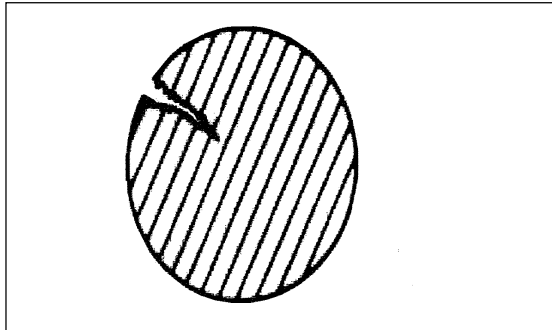

A discontinuity in the form of a crevice that is visible to the naked eye. The crack is clearly delineated by sharp edges and is of uniform width; it may occur only at the surface or extend through the entire section. This may typically occur in bonding some other metal to a platinum casting.

*Possible Causes:* Careless or improper heat treating; or, bonding hot metal with different coefficient of thermal expansion.

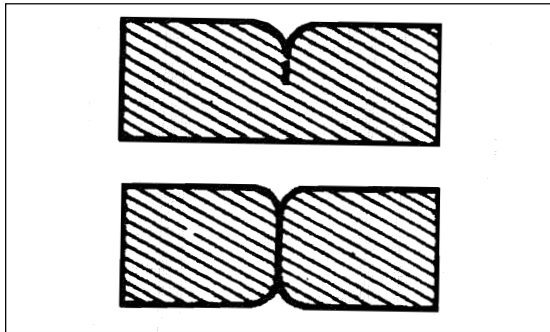
**Cold Shut or Cold Lap:**

A linear discontinuity with rounded edges. The defect has a characteristic appearance and may vary in depth. In the mildest case, it may consist merely of a shallow groove with rounded edges. A cold shut occurs on wide surfaces of the casting, in thin sections that are difficult to fill or where two streams of metal converge in the mold due to the sequence of filling.

*Possible Causes:* Inadequate gating; or improper casting parameters.

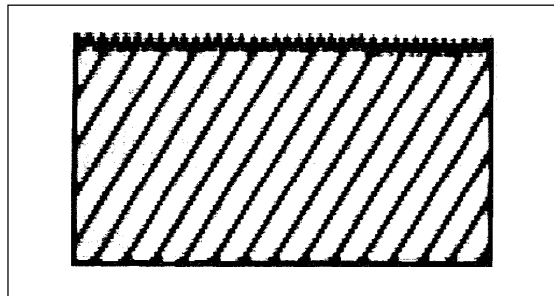
**Category D:**  
Defective Surface*Surface Folds or Gas Runs:*

Irregular fold marks distributed across a surface of the casting. This defect most often occurs on thin sections, which are remote to the gating of the pattern.

*Possible Causes:* Improper casting parameters (metal too hot, pour too slow, flask too cold). This is also due to the solution of gases from any source during the casting into the melt. This symptom may also appear if the wax pattern was not properly smooth or repaired.

### *Metal-Mold Reaction, Orange Peel and Alligator Skin:*

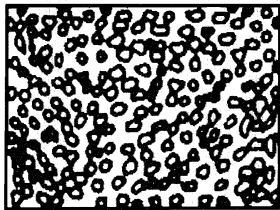

This is a defect where areas of the casting are covered with hollow blemishes resembling an orange peel. Dimensions of the blemishes may vary according to the severity of the condition. They are larger on thick heavy sections.

*Possible Causes:* Improper casting parameters (everything too hot and too fast). This can also be caused by substandard investment at the casting surface.

### *Sink Marks, Draw and Suck-In:*

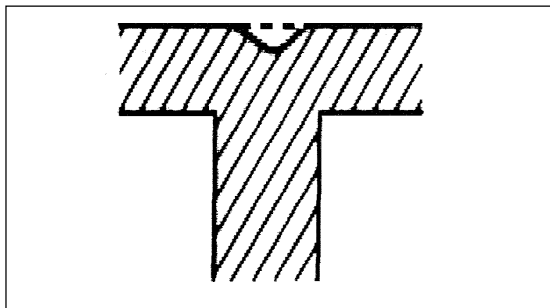

These are depressions in the casting surface at heavy metal sections and intersections. The surface of the depression is normally no different than that of other areas of the casting.

*Possible Causes:* Solidification contraction (surface collapse) where the pattern was improperly gated. Possibly a “wax sink” which was merely replicated in metal.

### External Slag Inclusions:

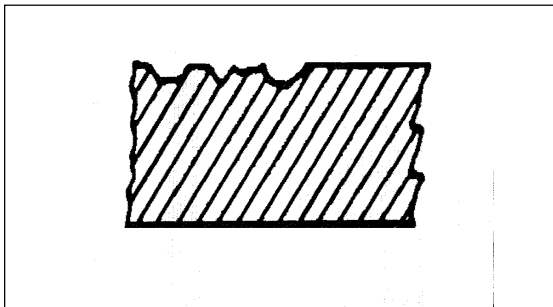

These are small shallow angular surface cavities of varying widths. They are typically uniform in their depth and are more prevalent toward the top of the mold.

*Possible Causes:* A reaction between the metal and the ceramic in the mold or the crucible. Any other contamination during the casting process can generate this defect as well, such as the  $O_2$  in the atmosphere forming oxides (slag) in the melt.

### Metal Penetration:

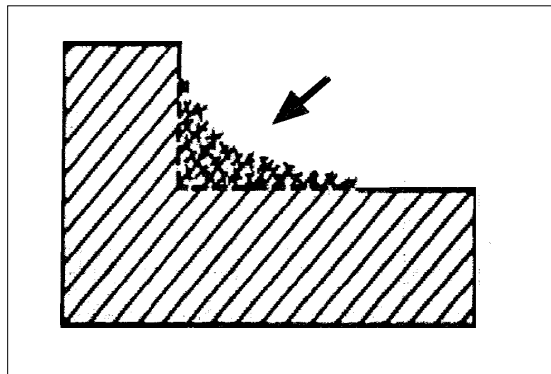

Contrary to the name, this defect is actually a projection of metal at the surface of no particular geometric shape, comprised of an intimate mixture of investment material and metal having a spongy appearance, but strongly adhering to the casting. This defect typically occurs in hot sections of the casting.

*Possible Causes:* Improper (too hot or forceful) casting parameters. Poor quality investment material.

### Dip Coat Spall, Scab:

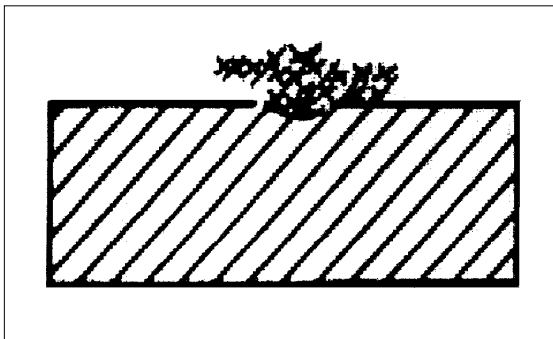

This is a defect that occurs when a flake or piece of mold material is trapped within the metal surface.

*Possible Causes:* Total or partial spalling of dipcoat. This can be the result of a general lack of adherence between coating layers of the ceramic; it can also be due to an improper formulation, application, drying of the ceramic or improper adhesion of the ceramic to the wax.

### Category E: Incomplete Casting

#### Misrun

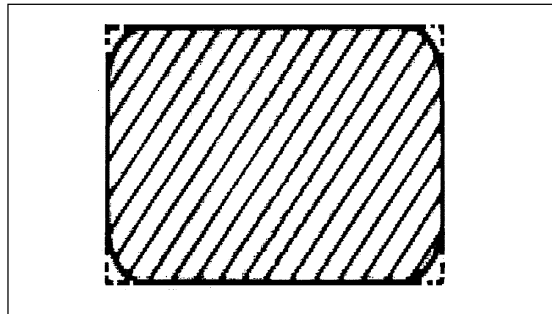

This is a defect where a portion of the casting is missing, usually distant from the gate area. Edges are rounded and the adjacent surfaces are generally shiny.

*Possible Causes:* Inadequate pouring temperature or flask too cold. The gating may be too small or improperly located with respect to the casting features. This can also be due to improper venting (permeability, vents or gating).

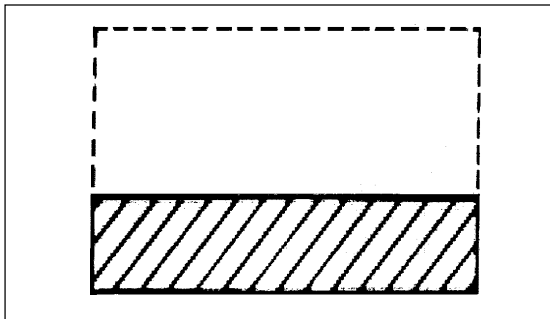
**Poured Short:**

The upper or extended areas of the casting are not filled. The edges adjacent to the missing section are slightly rounded; all other contours conform to the original pattern. The sprue, gates and pattern are all filled to the same height on the casting.

*Possible Causes:* Insufficient quantity of metal poured. This can also be due to an interruption of the pour, which does not allow the molten metal into the mold.

**Category F:**

Incorrect Dimensions or Shape

*Mutilation:*

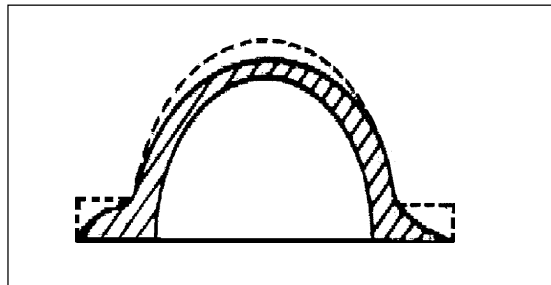

Areas of the casting are thinner than the pattern or they are deformed in relation to the original pattern.

*Possible Causes:* Mutilation of pattern features after casting caused from dropping, twisting and knocking. This can also be due to excessive cleaning or grinding of the pattern during finishing.

### Improper Shrinkage Allowance:

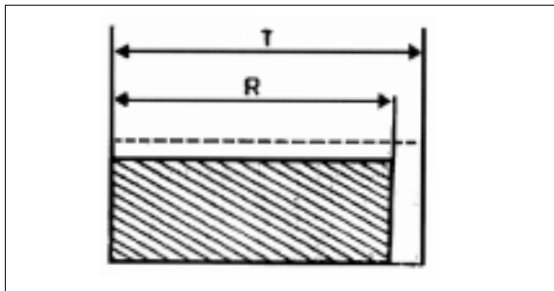

All measurements of the casting are uniformly large or small in comparison to the specified dimensions.

*Possible Causes:* The shrink rule used in making the pattern was incorrect and differed from the actual shrinkage of the alloy used.

### Casting Distortion:

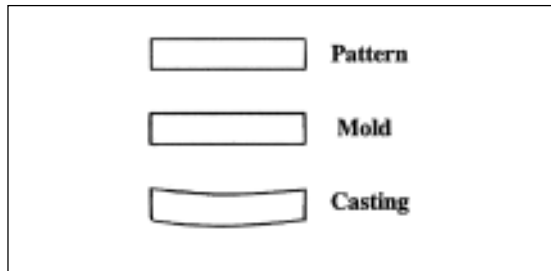

The casting displays overall distortion in comparison with the original pattern and the mold. Such distortions occur in long, flat areas or where changes in thickness take place.

*Possible Causes:* Restrained contraction due to casting design, gating design or overall mold construction or arrangement. An investment material that is too weak to resist normal mold contraction can also cause this.

## Category G:

Inclusions or Structural Anomalies

*Slag, Dross or Other  
Cerioxide Inclusions:*

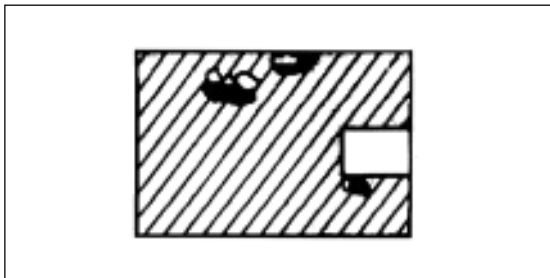

Irregularly shaped non-metallic inclusions resembling a ceramic material. These inclusions may occur below the casting surface and may not be visible until the piece is finished and polished.

*Possible Causes:* The origin of the inclusion may be from a contamination in the metal source or from the crucible where the melt is prepared or from loose ceramic or foreign material in the mold itself.

*Hard Spots:*

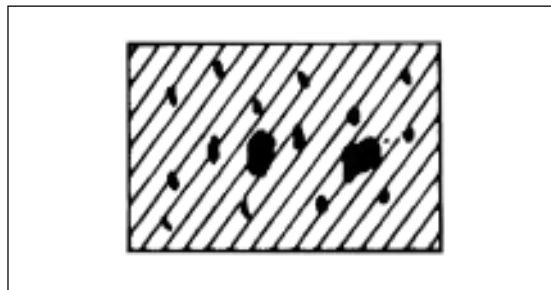

Hard inclusions, more or less finely dispersed and sometimes rather large. The casting may appear brittle and will display cracking if only slightly bent.

*Possible Causes:* Contamination by foreign material like silica, carbon, etc.

## Defect Analysis

Once the defect has been properly identified, all the causes must be examined in order to pinpoint the true root cause of

the problem. It is generally true that “there is usually enough skill in a company to identify and diagnose the technical aspect of the main problems.”<sup>6</sup> This should be a team effort that involves the quality techniques of *brainstorming* to uncover all possible contributions to the defect and the *fishbone diagram* to lead the way to corrective action.<sup>7</sup>

## Brainstorming

This is a common method to creatively get a high volume of input into a problem. A brainstorming session starts with a group whose participants all have information on the detected defect. A central question is posed, e.g., “What has caused this problem?” All members give their ideas while one person writes down the suggestions. A central concept to this strategy is that no idea is criticized. All suggestions are used

as springboards for additional ideas. Ideas are solicited during this session until all possibilities are exhausted. The group reviews the list and duplicate ideas are discarded.<sup>8</sup> This list be-

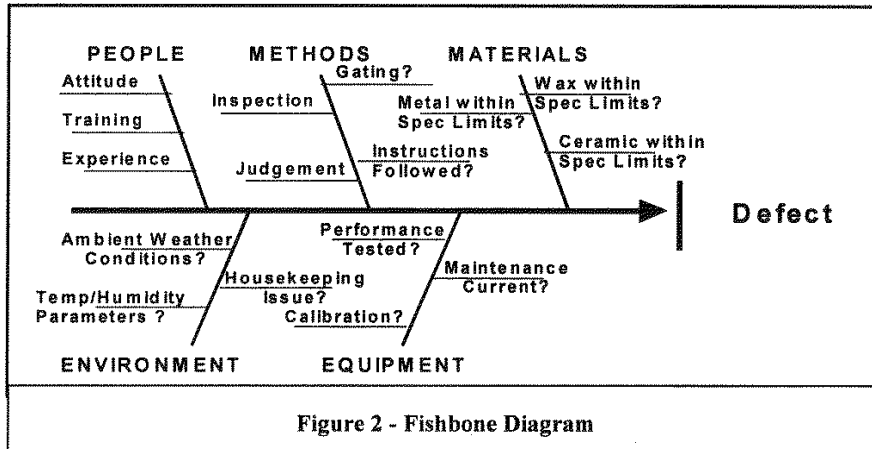

Figure 2 - Fishbone Diagram

comes the basis for the evaluation of the root cause. The group can then discuss and determine the most likely root cause of the defect. Once the root cause has been determined, corrective action can be taken to insure the problem will not recur.

## The Fishbone Diagram

The fishbone diagram is another method for identifying defect causes. The “fishbone” (*see figure 2*) takes an effect (defect) and traces its possible causes using the five factors of a process—People, Methods, Materials, Equipment and Environment. A team draws out the skeleton of the fishbone by identifying all the possible sources of variation in the process. Any variation of the process that occurred concurrent with the defect is documented on this tool. Minor excursions from the process or any special process events are listed. There are many process variables, which can contribute to defects. The fishbone diagram can efficiently identify the significant sources of the variation and allow the

proper corrective action to be initiated.

## Corrective Action

The correction of defects will vary depending upon the root cause. With regard to sporadic defects, “the cause and effect relationship is often simple and localized.”<sup>9</sup> The corrective action for these defects will either involve making some change in the process to avoid the defect; or, corrective action will involve controls to keep the process from deviating from its proven path again.

The observation of one defective piece does not inevitably imply that the process is out of control. It has been well established that “predictable performance is not necessarily the same as desirable performance.”<sup>10</sup> With all the process variables moving within their natural state of control, a defect can occur that can only be explained by a slight drift of a key control characteristic. If a control limit is marginal, i.e., sometimes results in a defect and sometimes not; then,

the control limit will have to be made artificially tighter to disallow the potential for problems. For instance, if spalling is a problem, the useful life of a slurry may be arbitrarily set at a shorter time frame even though all the recordable variables remain in apparent control beyond that point.

If the cause of a defect is related to quasi-controlled variables such as gating, investment, firing or casting techniques; then, the ideal corrective action would be to improve the application of these methods for the type of patterns which cause the difficulty. For instance, if a design that has fine detail along with thick sections does not cast well with standard gating and casting parameters, amend the gating to accommodate the appropriate casting method. After a few such occurrences, an established process is developed for complex geometry patterns.

Of course, the defect analysis may uncover that the special cause of the problem is due to an avoidable process

error. If the defect was caused by violation of control limits or improper application of established process variables, the corrective action is to insure that the system will not allow such excursions to take place again. This can be done by:<sup>11</sup>

1. *Elimination*: Redesigning the process so the task with the potential error is no longer necessary.
2. *Replacement*: Substituting a more reliable process for the employee.
3. *Facilitation*: Making the work easier to perform, e.g., color-coding, posted instructions, etc.
4. *Detection*: Detecting an error before further processing, e.g., sequential checklist, observer, software, etc.
5. *Mitigation*: Minimizing the effect of the error.

In any case, corrective action must

include some documentation of all the important information derived from the identification and analysis of the defect. The course of action must be communicated to all process participants and the changes to correct the defect must be integrated immediately into the process. Process control must be updated regularly by process correction.

In conclusion, defects observed in the output of the casting process need to be identified, analyzed and corrected. Mere inspection of the output will not improve the quality of the final product. As Philip Crosby has stated, "The system for causing quality is prevention, not appraisal."<sup>12</sup> It is unavoidable that a defect will occur even in a tightly controlled process. Preventing that defect from recurrence is the only way to ensure that a designer's vision will be realized in a casting. Platinum casters need to pursue the elimination of defects as an unrelenting detective pursues a suspect in order to unlock the secrets in the investment casting

process. The mystery of sporadic defects must be solved to insure that a casting customer get a superior product and not repetitious excuses. The only way to attain this goal is with a well-controlled and monitored process

### Bibliography

1. Ott, Dieter, Handbook on Casting and Other Defects, World Gold Council, London, 1997. p. 6.
2. Juran, J.M., Quality Planning and Analysis, Third Edition, McGraw-Hill, Inc., New York, NY, 1993, p. 54.
3. Juran, J.M., *Quality Problems, Remedies and Nostrums*, <http://www.juran.com> 1998, p.11.
4. Rowley, Mervin T., International Atlas of Casting Defects, American Foundrymen's Society, Des Plaines, IL, 1974, p.5.

5. Ibid., p.5.
6. Juran, J.M., *Industrial Diagnostics—A Systematic Approach*, <http://www.juran.com>, 1998, p.8.
7. Fine, Edmund S., *Solve Problems with the Appropriate SPC Tool*, Quality Magazine, August 1997.
8. Brassard, Michael and Ritter, Diane, The Memory Jogger II, GOAL/QPC, Methuen, PA, 1994, pp. 19-22.
9. Juran, J.M., *Quality Problems, Remedies and Nostrums*, <http://www.juran.com>, 1998, p.12.
10. Wheeler, Donald J., *Some Days Are Better Than Others*, Quality Magazine, June, 1998.
11. Juran, Quality Planning and Analysis, p. 348.
12. Crosby, Philip, Quality Without Tears, McGraw-Hill, New York, 1984, p. 73.