

Efficient melting in coreless induction furnaces

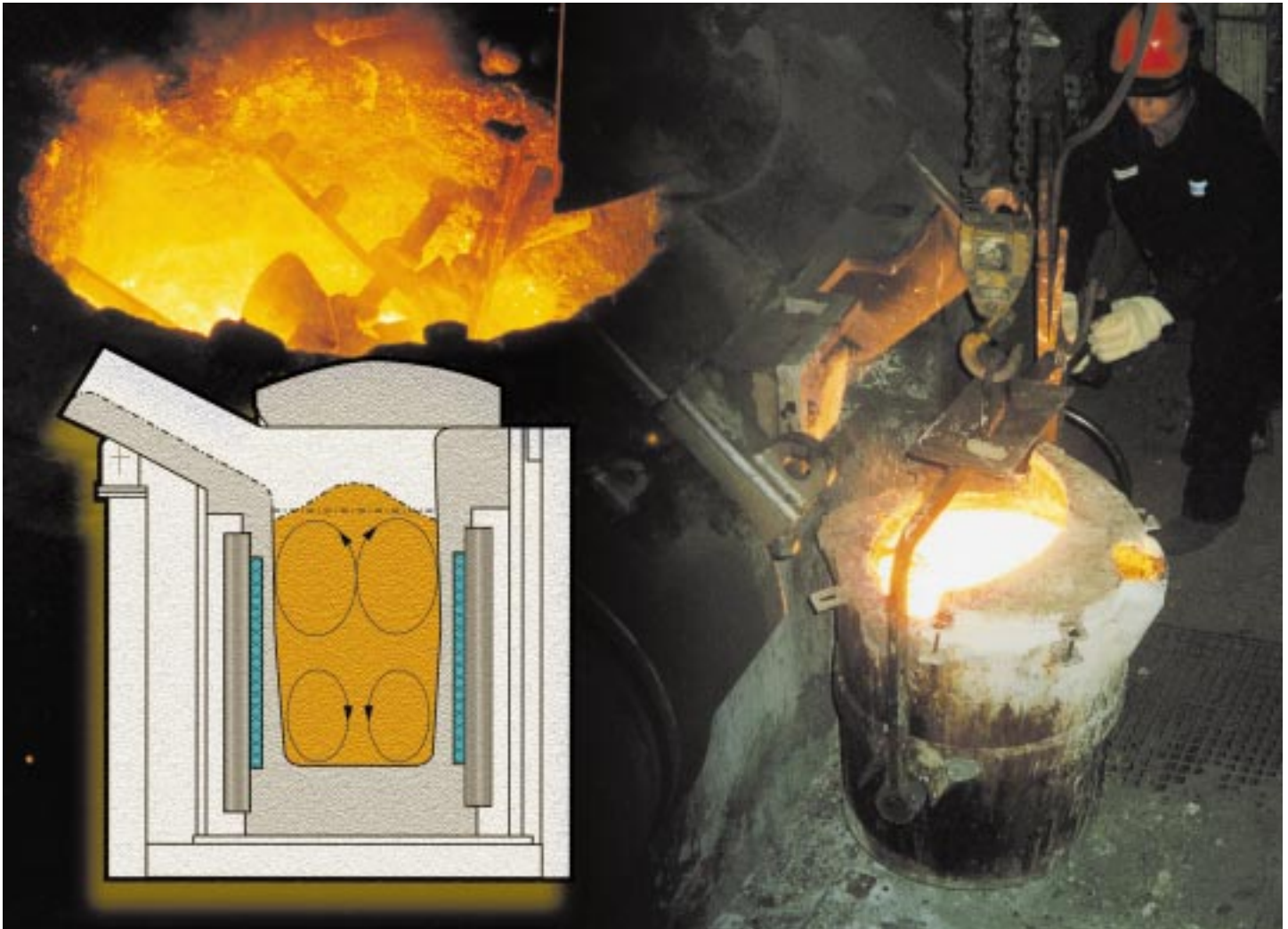

ENERGY EFFICIENCY

BEST PRACTICE
PROGRAMME

EFFICIENT MELTING IN CORELESS INDUCTION FURNACES

This Guide is No. 50 (revised) in the Good Practice Guide Series and provides advice on practical ways of improving the energy efficiency of coreless induction furnaces in ferrous foundries. It reviews the various factors that affect energy efficiency, from selection of the furnace and suitability of raw materials, through to charging, operation and control. The importance of energy management is highlighted, and information on environmental and safety considerations is provided.

Prepared for the Energy Efficiency Best Practice Programme by:

ETSU
Harwell
Didcot
Oxfordshire
OX11 0RA

LIST OF RELEVANT GOOD PRACTICE GUIDES

2. ENERGY SAVINGS WITH ELECTRIC MOTORS AND DRIVES
13. WASTE HEAT RECOVERY FROM HIGH TEMPERATURE GAS STREAMS
14. RETROFITTING AC VARIABLE SPEED DRIVES
17. ACHIEVING HIGH YIELDS IN IRON FOUNDRIES
49. ENERGY EFFICIENT LADLE PRE-HEATING TECHNIQUES WITHIN THE STEEL INDUSTRY
58. CUPOLA MELTING OF CAST IRON IN IRON FOUNDRIES
63. METAL DISTRIBUTION AND HANDLING IN IRON FOUNDRIES
68. ELECTRIC HOLDING OF HOT METAL IN IRON FOUNDRIES
69. INVESTMENT APPRAISAL FOR INDUSTRIAL ENERGY EFFICIENCY
76. CONTINUOUS STEEL REHEATING FURNACES: SPECIFICATION, DESIGN AND EQUIPMENT
77. CONTINUOUS STEEL REHEATING FURNACES: OPERATION AND MAINTENANCE
84. MANAGING AND MOTIVATING STAFF TO SAVE ENERGY
85. ENERGY EFFICIENCY TRAINING AND DEVELOPMENT
91. MONITORING AND TARGETING IN LARGE MANUFACTURING COMPANIES
111. MONITORING AND TARGETING IN FOUNDRIES
112. MONITORING AND TARGETING IN LARGE COMPANIES
125. MONITORING AND TARGETING IN SMALL AND MEDIUM-SIZED COMPANIES
126. COMPRESSING AIR COSTS
142. IMPROVING METAL UTILISATION IN ALUMINIUM FOUNDRIES
166. ENERGY SAVING IN FOUNDRY SERVICES
168. CUTTING YOUR ENERGY COSTS
169. TOTAL QUALITY MANAGEMENT
213. SUCCESSFUL PROJECT MANAGEMENT FOR ENERGY EFFICIENCY
214. MAKING USE OF BUSINESS STANDARDS
215. REDUCING ENERGY COSTS IN INDUSTRY WITH ADVANCED COMPUTING AND CONTROL
217. CUTTING ENERGY LOSSES THROUGH EFFECTIVE MAINTENANCE (TOTALLY PRODUCTIVE OPERATIONS)
235. MANAGING PEOPLE, MANAGING ENERGY
241. ENERGY SAVINGS IN THE SELECTION, CONTROL AND MAINTENANCE OF AIR COMPRESSORS
251. MAINTAINING THE MOMENTUM: SUSTAINING ENERGY MANAGEMENT
252. BURNERS AND THEIR CONTROLS

Copies of these Guides may be obtained from:

Energy Efficiency Enquiries Bureau
ETSU
Harwell
Didcot
Oxfordshire
OX11 0RA
Fax No: 01235 433066
Helpline Tel No: 0800 585794
Helpline E-mail: etbppenvhelp@eat.co.uk

Overseas customers please remit £3 per copy (minimum of £6) with order to cover cost of packaging and posting. Please make cheques, drafts or money orders payable to ETSU.

FOREWORD

This Guide is part of a series produced by the Government under the Energy Efficiency Best Practice Programme. The aim of the programme is to advance and spread good practice in energy efficiency by providing independent, authoritative advice and information on good energy efficiency practices. Best Practice is a collaborative programme targeted towards energy users and decision makers in industry, the commercial and public sectors, and building sectors including housing. It comprises four inter-related elements identified by colour-coded strips for easy reference:

- *Energy Consumption Guides*: (blue) energy consumption data to enable users to establish their relative energy efficiency performance;
- *Good Practice Guides*: (red) and *Case Studies*: (mustard) independent information on proven energy-saving measures and techniques and what they are achieving;
- *New Practice projects*: (light green) independent monitoring of new energy efficiency measures which do not yet enjoy a wide market;
- *Future Practice R&D support*: (purple) help to develop tomorrow's energy efficiency good practice measures.

If you would like any further information on this document, or on the Energy Efficiency Best Practice Programme, please contact the Environment and Energy Helpline on 0800 585794. Alternatively, you may contact your local service deliverer – see contact details below.

ENGLAND

London

Govt Office for London
6th Floor
Riverwalk House
157-161 Millbank
London
SW1P 4RR
Tel 020 7217 3435

East Midlands

The Sustainable Development Team
Govt Office for the East Midlands
The Belgrave Centre
Stanley Place
Talbot Street
Nottingham
NG1 5GG
Tel 0115 971 2476

North East

Sustainability and Environment Team
Govt Office for the North East
Wellbar House
Gallowgate
Newcastle-upon-Tyne
NE1 4TD
Tel 0191 202 3614

North West

Environment Team
Govt Office for the North West
Cunard Building
Pier Head
Water Street
Liverpool
L3 1QB
Tel 0151 224 6401

South East

Sustainable Development Team
Govt Office for the South East
Bridge House
1 Walnut Tree Close
Guildford
Surrey
GU1 4GA
Tel 01483 882532

East

Sustainable Development Awareness Team
Govt Office for the East of England
Heron House
49-53 Goldington Road
Bedford
MK40 3LL
Tel 01234 796194

South West

Environment and Energy Management Team
Govt Office for the South West
The Pithay
Bristol
Avon
BS1 2PB
Tel 0117 900 1700

West Midlands

Regional Sustainability Team
77 Paradise Circus
Queensway
Birmingham
B1 2DT
Tel 0121 212 5300

Yorkshire and the Humber

Sustainable Development Unit
Govt Office for Yorks and the Humber
PO Box 213
City House
New Station Street
Leeds
LS1 4US
Tel 0113 283 6376

NORTHERN IRELAND

IRTU Scientific Services
17 Antrim Road
Lisburn
Co Antrim
BT28 3AL
Tel 028 9262 3000

SCOTLAND

Energy Efficiency Office
Enterprise and Lifelong Learning Dept
2nd Floor
Meridian Court
5 Cadogan Street
Glasgow
G2 6AT
Tel 0141 242 5835

WALES

Business and Environment Branch
National Assembly for Wales
Cathays Park
Cardiff
CF10 3NQ
Tel 029 2082 5172

MANAGEMENT SUMMARY

A recent Energy Consumption Guide¹ published by the Energy Efficiency Best Practice Programme indicated that, in 1998, the UK ferrous foundry industry consumed 4.55 million TWh of delivered energy, valued at £102 million, in producing 1.4 million tonnes of iron castings and 100,000 tonnes of steel castings. As much as 65% of this energy was utilised in the melting and holding of molten metal.

In recent years there has been a continuing move away from cupola to electrical induction melting, primarily to enable foundries to produce a wider range of alloys more readily and to help them to meet increasing environmental legislation.

Currently, over 50% of iron castings are made from metal melted by electrical induction, and all steel castings are produced from metal melted either by electrical induction or in arc furnaces.

The objective of this Good Practice Guide is to review the operating procedures for coreless induction furnaces which have a bearing on the energy consumption per tonne of metal melted. Undoubtedly, attention to good operating practices can reduce the energy costs for melting iron in the majority of foundries. Some of the key messages from this Guide include:

- The first requirement when endeavouring to improve energy consumption is to quantify the amount of energy used and metal charged. Surprisingly, it is not uncommon for coreless furnaces to be operated without energy consumption being measured, either because meters are not fitted or because usage is not monitored.
- The condition of the feedstock can make a substantial difference to the energy needed to melt it. If unsuitable materials are used, an investigation will verify whether any hidden costs outweigh the apparent savings achieved by purchasing cheaper raw material.
- Furnaces are more efficient in their use of energy when they are operated at maximum power input levels; optimum results are obtained when the available power can be fully utilised for the largest proportion of the melting cycle.
- Excessive superheating or long holding times at high temperature is wasteful and can lead to metallurgical problems.
- The use of furnace lids assists in conserving energy, although badly fitting lids and their unnecessary or prolonged opening can have an adverse effect on costs.

This Guide represents the current state of knowledge of melting iron in coreless induction furnaces. When the previous version of this Guide was produced in 1992, many foundries operated mains frequency (50 Hz) furnaces. However, since its publication, coreless furnaces operating at medium frequency rather than mains frequency now predominate, particularly for melting purposes, and it is anticipated that this situation will continue for the foreseeable future.

¹ ECG 48, *Energy consumption in ferrous foundries (second edition)*, 1999

CONTENTS

Section		Page No.
1.	INTRODUCTION	1
1.1	Overview	1
2.	BACKGROUND	2
2.1	The Coreless Induction Furnace	2
2.1.1	Description	2
2.1.2	Mains and Medium Frequency	2
2.1.3	Principles of Operation	3
2.2	Energy Consumption in Iron Foundries Melting by Induction	6
3.	KEY MESSAGES	9
4.	SELECTION OF NEW CORELESS MELTING PLANT	11
4.1	General	11
4.2	Important Furnace Design Characteristics	12
4.2.1	Mains vs. Medium Frequency	12
4.2.2	Influence of Furnace Capacity and Power Density	13
4.2.3	Automatic Power Control and Monitoring	14
4.2.4	Optimising Furnace Design	14
5.	CHARGE MATERIALS AND CHARGING OPERATIONS	16
5.1	Overview	16
5.2	Condition of Charge Metallics	16
5.2.1	Cleanliness	16
5.2.2	Size	17
5.2.3	Additional Materials	17
5.2.4	Storage	17
5.3	Furnace Charging Techniques	19
6.	FURNACE OPERATION AND CONTROL	22
6.1	Overview	22
6.2	Efficient Melt Scheduling	22
6.3	Metering Energy Usage	22
6.4	Computer Control of Furnace Operation	22
6.5	Control of Chemical Composition	24
6.6	Temperature Control	24
6.7	Slag Removal	25
6.8	Holding Molten Iron	25
7.	FURNACE LINING PRACTICE	27
7.1	Overview	27
7.2	Coil Protection	27
7.3	Crucible Material	27
7.4	Lining Performance	27
7.5	Lining Removal	28
8.	ENERGY MANAGEMENT	30
8.1	Overview	30
8.2	Factors Influencing Output and Energy Consumption	30
8.3	Electricity Charges	32
8.4	Power Factor	33
8.5	Casting Yield	33

Section		Page No.
9.	ENVIRONMENTAL CONSIDERATIONS	34
10.	WASTE HEAT UTILISATION	35
10.1	General	35
10.2	Drying Raw Materials	35
11.	SAFETY CONSIDERATIONS	36
APPENDIX 1	PRINCIPLES OF ELECTRICAL INDUCTION MELTING	37
A1.1	Furnace Design	37
A1.2	Power Supplies	37
A1.3	Penetration Depth of Induced Current	38
APPENDIX 2	SAFETY	39
A.2.1	General Hazards and Precautions	39
A.2.2	Hazards Associated with Induction Melting	39

FIGURES

Fig 1	Typical arrangement for a coreless induction melting furnace	2
Fig 2	Relationship between melting rate and furnace capacity (manufacturers' quoted data)	3
Fig 3	Stirring action generated by magnetic field	4
Fig 4	Power sharing arrangement	5
Fig 5	Basic electric circuit for a medium frequency coreless furnace	6
Fig 6	Energy cost of melting vs. throughput	7
Fig 7	Typical energy usage in a large iron foundry	7
Fig 8	Typical energy usage in a small iron foundry	8
Figs 9a and 9b	Relationship between power density and furnace size	12
Fig 10	Effect of power density on energy consumption	13
Fig 11	Energy consumption for holding iron in coreless furnaces of various capacities	13
Fig 12	Energy losses in a mains frequency coreless furnace (Sankey diagram)	14
Fig 13	Vibratory charging machine	20
Fig 14	Furnace status screen	23
Fig 15	Power supply screen	23
Fig 16	Cooling water temperature screen	24
Fig 17	Back-tilting facility for de-slagging	25
Fig 18	Lining push-out arrangement	28
Fig 19	Pre-formed crucible	29
Fig 20	Actual melting rates in medium frequency furnaces	30
Fig 21	Influence of tapping frequency on melting performance	32
Fig 22	Circuit diagram of a parallel inverter	37
Fig 23	Circuit diagram of a series inverter	38

TABLES

Table 1	Key messages - action list	9
Table 2	Effect of rusty scrap charge on energy consumption	16
Table 3	The effect of inadequate raw material control on iron castings quality	18
Table 4	Effectiveness of furnace lids on radiated heat losses	19
Table 5	Effect of lining performance	28
Table 6	Energy consumption in coreless induction furnaces under optimum and practical operating conditions	31

1. INTRODUCTION

Typically, the melting department accounts for more than half the total energy costs for the operation of an iron foundry.

A modern, coreless furnace can melt a tonne of iron and raise the temperature of the liquid metal to 1,450°C using less than 600 kWh of electricity. However, in practice, only a few foundries achieve this level of energy consumption on a week-by-week basis, while others use as much as 1,000 kWh for every tonne of iron produced. Although prevailing circumstances in many foundries can restrict the scope for good energy management, almost all coreless melting operations could be improved to give a worthwhile saving in energy costs.

Energy Consumption Guide 48, *Energy consumption in ferrous foundries*, was updated in 1999. The wide range of specific energy consumption (SEC) values reported in the melting departments of the foundries surveyed indicates considerable potential for reducing energy usage. If the energy costs of electric melting and holding were reduced by 10%, the average operating cost of manufacture would decrease by approximately £7.70 per tonne. This would have an immediate and positive influence on profitability. For many foundries these levels of savings should be possible.

This Guide reviews factors that influence energy efficiency, namely the correct selection of melting unit, suitability of raw materials, effective charging, and optimum furnace operation and control. Advice is given on furnace lining practice and monitoring refractory performance. The importance of energy management and its relationship to furnace design, coil geometry, lining construction, power supply, power factor correction, and so on, is highlighted. Finally, information on environmental and safety considerations is provided.

1.1 Overview

This Guide outlines the thought process associated with buying and specifying a coreless induction melt unit for a foundry, then actually installing and operating one. Each step can have an impact on the foundry's energy consumption and costs. Covering the following key points, this Guide provides advice on performing tasks in the most energy efficient manner:

1. Should electrical induction melting be considered? Is it right for the likely output and product mix from the foundry, taking into consideration factors such as: the need for flexibility; emission control; energy and other running costs; maintenance; and local conditions?
2. Correct specification - what is the optimum unit size and type, taking into account throughput, range of metals, likely future demands, etc.? This is covered in Sections 3 and 4. Specification is very important: as with many electrically-powered items, the cost of electricity consumed over a typical lifetime can be many times more than the original outlay. Specifying and using an inappropriate induction melting unit can prove a false economy.
3. Correct use - once the foundry has specified and installed an induction melting unit, how best to operate it? Control of melting, through best operating practices, the importance of metal and optimising scheduling to fit in with rest of foundry are all crucial to efficient operation. These topics, and more, are covered in Sections 5, 6 and 8.
4. What are the key considerations concerning maintenance, repair and replacement - including lining, lids, cooling water, etc.? Guidance is given in Section 7.
5. Can the foundry do something with the waste heat from the units? Some ideas are given in Section 10.

2. BACKGROUND

2.1 The Coreless Induction Furnace

2.1.1 Description

Most coreless induction furnaces consist of a robust steel shell that is mounted on trunnions and fitted with a mechanism for tilting, usually by hydraulic power (Fig 1); however, some furnace bodies are of open frame or concrete block construction. The furnace normally comprises a cylindrical refractory, the top of which is open for charging and de-slagging operations. A spiral, water-cooled electrical coil is mounted within the body shell. On all but the smallest furnaces, a refractory-lined swing lid is provided to reduce heat losses from the surface of the liquid metal; many units employ this facility to extract the fume and particulate generated.

Molten metal is transferred from an induction furnace into ladles, launders, etc., by tilting the furnace on its trunnions. The trunnions are normally fitted at the front of the furnace body in line with the pouring lip. The tilting mechanism is usually hydraulically powered.

A more detailed description of such furnaces is given in Appendix 1.

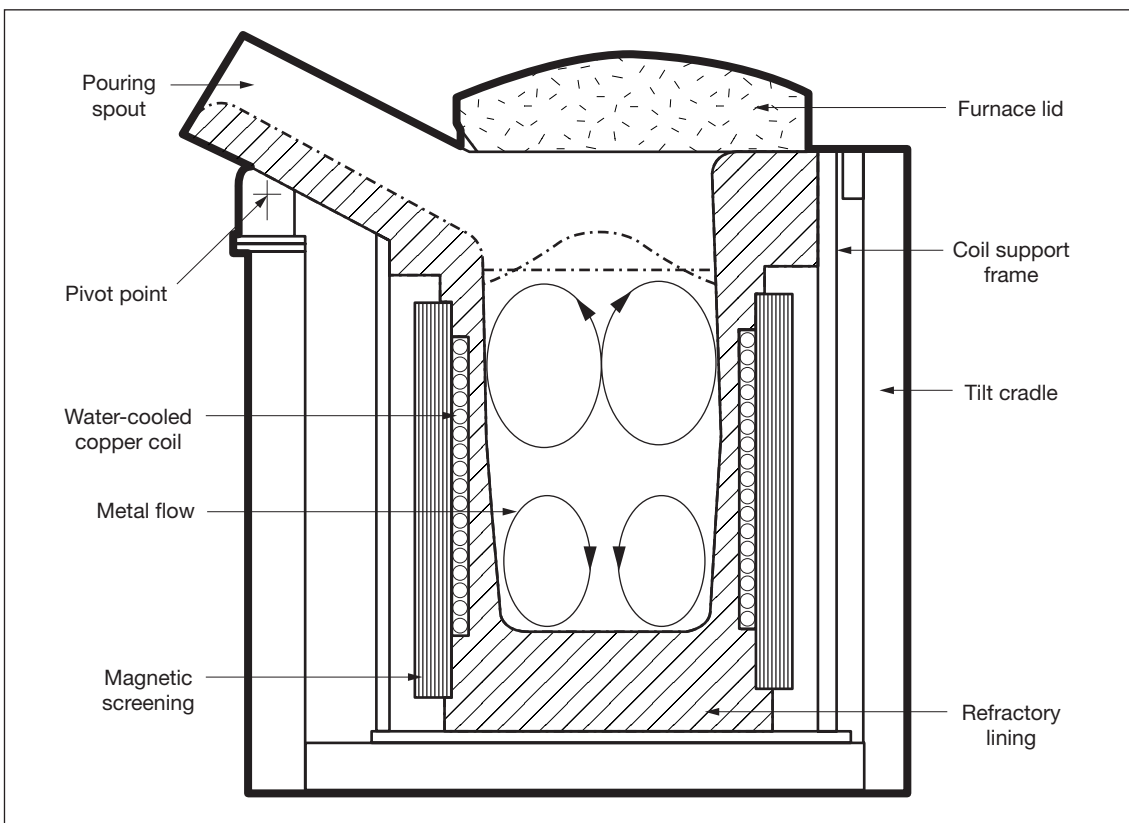

Fig 1 Typical arrangement for a coreless induction melting furnace

2.1.2 Mains and Medium Frequency

There are two main groups of coreless furnace, classified by the frequency of the alternating current applied:

- mains (or line) frequency furnaces which are normally operated at 50 Hz;
- medium frequency furnaces which may be operated from 150 Hz (triple line frequencies) up to 1,500 Hz.

Presently, furnaces operating in the 250 - 1,000 Hz range are the most popular.

The frequency of the current in the coil markedly affects the operating characteristics of the furnace.

- **Mains frequency furnaces**, when started from cold, require starter blocks (which normally have to be specially cast) and generally operate with a liquid heel equivalent to one-third capacity. This type of unit naturally produces a stirring action that results in better assimilation of additions to the molten metal, particularly carburising agents. However, the action imposes limitations on both furnace size and the power applied to the coil (to avoid liquid metal ejection and excessive lining erosion).

Power density is generally limited to 200 - 300 kW per tonne of furnace capacity and, if maximum power is to be drawn, a molten heel equivalent to two-thirds capacity must be maintained. Heat loss to the cooling water lies in the range of 20 - 30% of that generated.

- **Medium frequency furnaces** can be readily started from cold using a scrap charge, with the advantage that this allows rapid changeover of composition. The stirring action obtained is significantly less than in mains frequency furnaces, but greater in high power density, low frequency units.

High power densities of up to 1,000 kW per tonne of furnace capacity are employed and hourly melting rates equivalent to the furnace capacity at 100% utilisation are achievable, i.e. a full furnace of molten iron can be produced within one hour (Fig 2). The higher output, compared with mains frequency units for a given size of furnace (typically a 3:1 ratio), may reduce the space required for a particular melting plant.

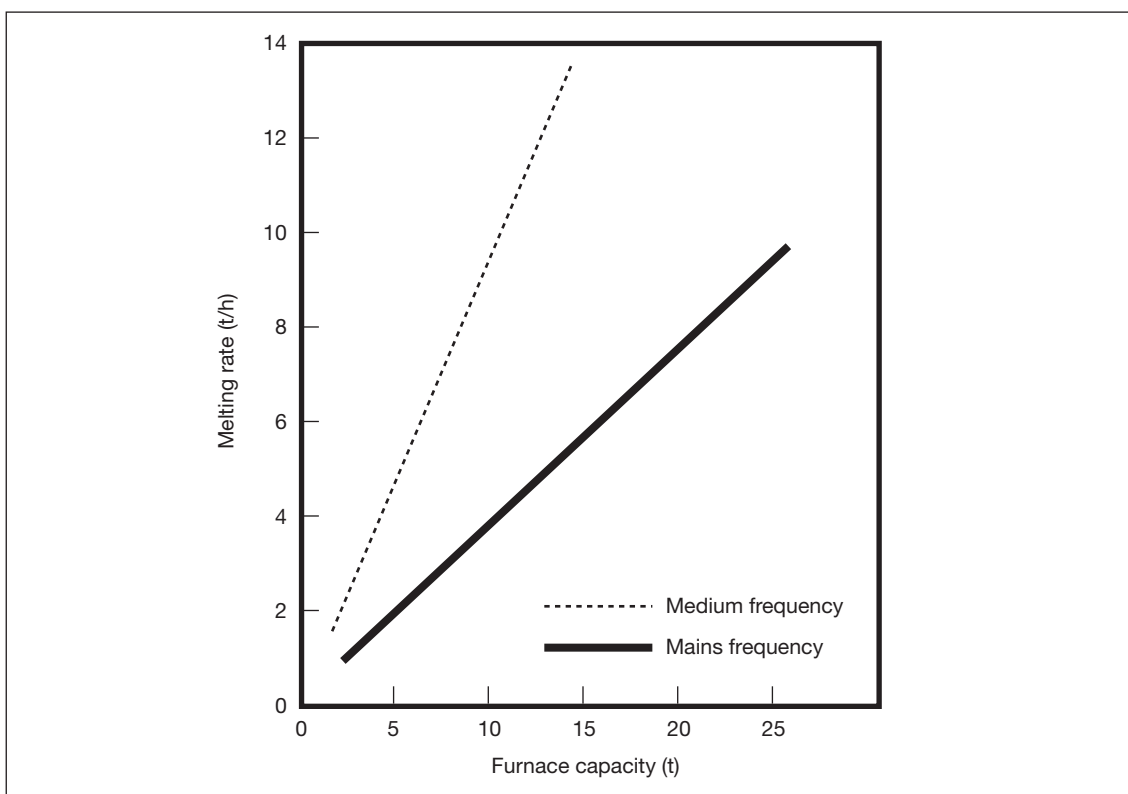

Fig 2 Relationship between melting rate and furnace capacity (manufacturers' quoted data)

2.1.3 Principles of Operation

An induction furnace operates on a similar principle to a transformer, i.e. the induction coil acts as a primary coil, having many turns, and the charge acts as a secondary coil, with only a single turn. When an alternating current is applied to the induction coil of a furnace, a significantly larger current is induced in the metallic charge materials.

The resistance to the passage of the induced current within the furnace charge causes the charge to heat up until it eventually melts. Once the metal is molten the magnetic field generated creates a stirring action (Fig 3) in the bath, producing both homogenisation of the chemical composition and assimilation of any bath additions.

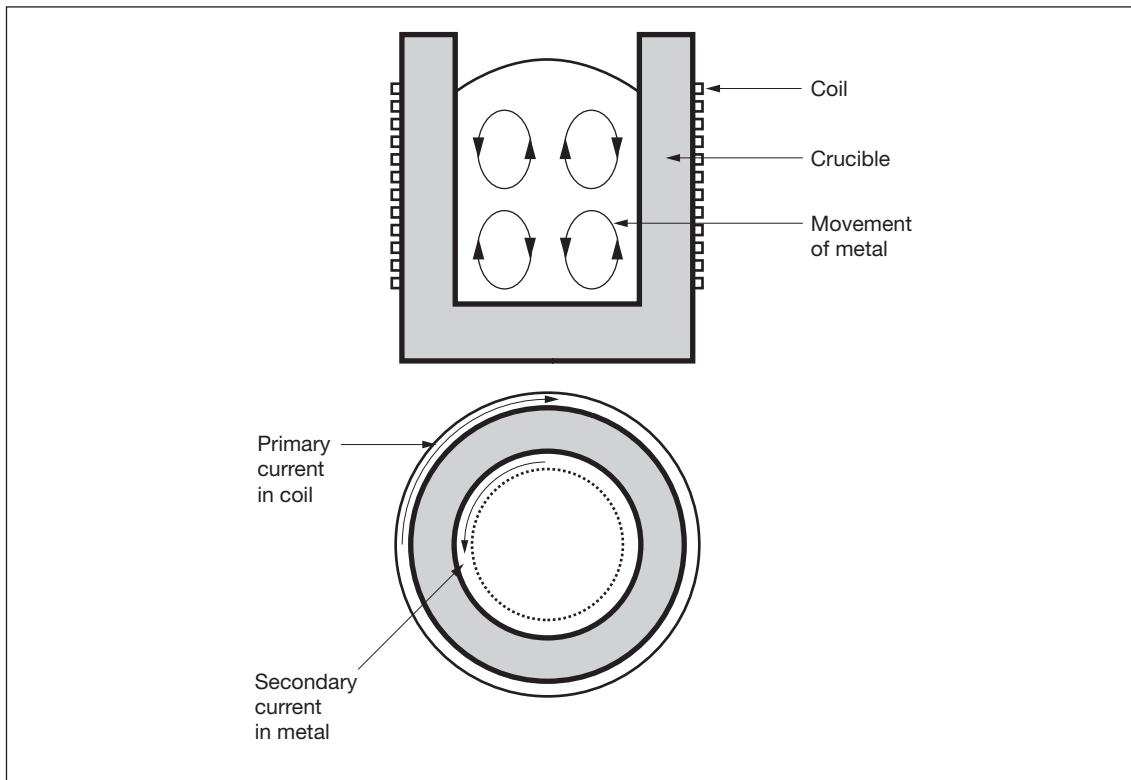

Fig 3 Stirring action generated by magnetic field

The flow of current through the induction coil generates heat in the coil itself. Heat is also conducted through the furnace refractory from the molten metal contained in the crucible. Efficient water-cooling is crucial to prevent the coil overheating and potential failure. Water-cooling systems are, therefore, designed to provide reliability, with several separate water-cooling circuits installed at the coil, each fitted with thermostats and a means to verify the flow of coolant. Because the safe operation of the furnace is of the utmost importance, manufacturers have devised various sensing systems that provide warning if liquid metal is penetrating the crucible refractory to a critical level.

The simplest arrangement for a unit is a single-furnace, power pack combination. This is the least expensive option and minimises running costs. As electric furnaces are batch melters, a single-furnace plant is only suitable for jobbing applications where iron is tapped-off as and when required. Where metal is required continuously to feed one or more moulding tracks, a multi-furnace installation is necessary. For example, with two furnaces, one will be in the melting mode while the second will be holding and dispensing metal for pouring. The power rating selected will ensure that the hourly metal output from the furnace plant matches the practical hourly metal demand from the foundry.

A two-furnace installation will have a single power pack and either a changeover switch (with conventional equipment) or, in more modern plants, 'power sharing' facilities (Fig 4). In the conventional unit, the changeover facility allows power to be applied to either furnace, as required. With power sharing, however, the total power available can be allocated to each furnace in any proportion from 100 - 0%. For example, one furnace could be run at full power, with no power being applied to the second furnace, or both furnaces could be run at holding power levels. The holding furnace power setting always dominates the control system, so the remaining power is then available for the melting furnace. Because holding power can be applied continuously to

the pouring furnace, precise control of metal temperature is maintained. With the power sharing approach, production output can be increased by as much as 20% and, unlike single output power units, there is no need for mechanical switching or a second power pack.

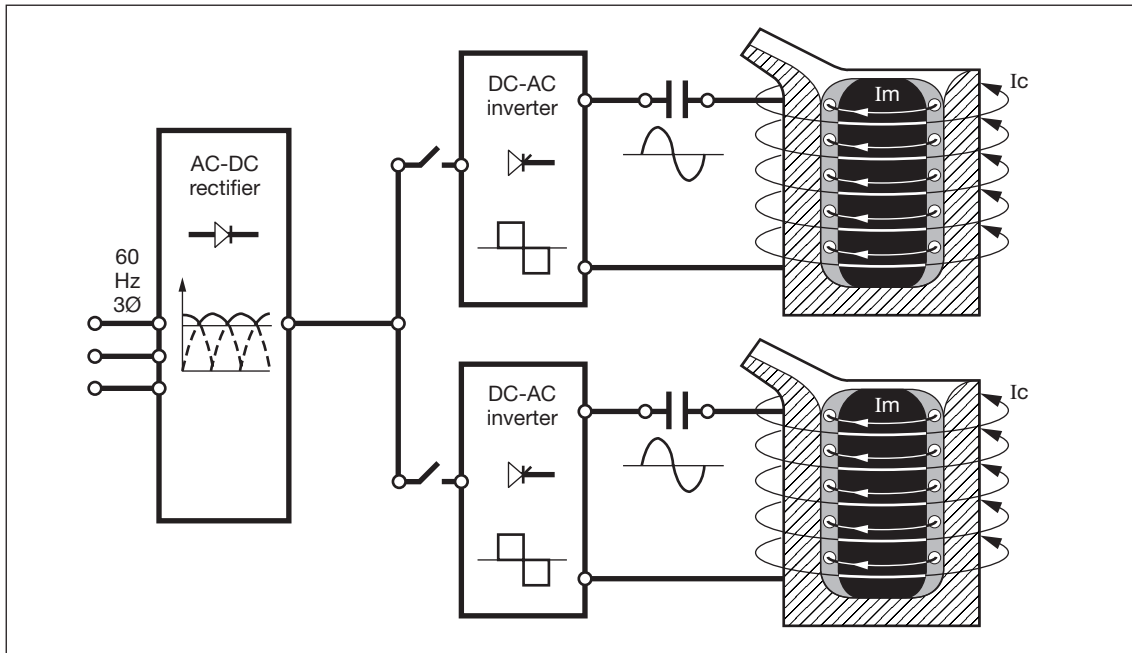

Fig 4 Power sharing arrangement

A further benefit of power sharing is its ability to sinter or cold-start two furnaces at the same time, or to sinter one furnace while melting in the other. This reduces production downtime and increases system output. The technology also allows full-rated power to be directed to one furnace by completely isolating the other during maintenance or lining changes.

A single, dual output power unit not only provides the batch production capability of two separate power supplies, but also:

- offers a significant saving in installation and maintenance costs;
- requires less space;
- offers a level of equipment utilisation approaching 100%, because it is designed to use its full power capability throughout the batch-melting cycle.

In general, it provides the minimum investment per tonne of metal poured. Many units of this type are operating worldwide, with power packs rated from 500 kW to 12.5 MW, the larger furnaces providing metal throughput in excess of 20 tonnes per hour.

Fig 5 shows the circuit for a medium frequency coreless induction-melting furnace.

An induction furnace is a highly inductive, single-phase load and hence, without correction, a very low power factor would apply. In ac circuits where there is a coil, the voltage and current can be 'out of phase', the difference being known as the power factor. A low power factor causes more current to be drawn from the supply than is necessary for the power required.

$$\text{Real power (kW)} = \text{volts} \times \text{amps} \times \text{power factor}$$

$$\text{Power factor} = \frac{\text{Real power (kW)}}{\text{Apparent power (kVA)}}$$

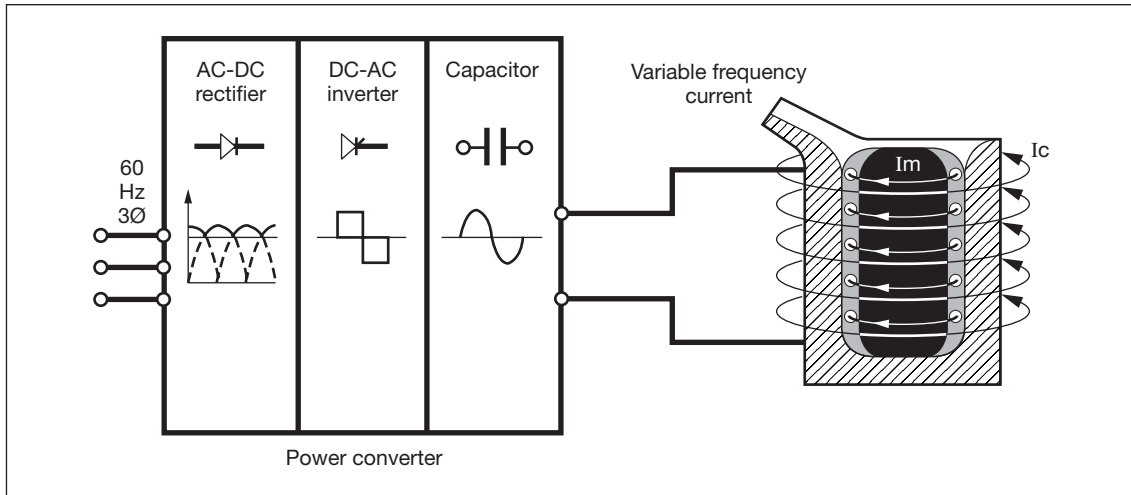

Fig 5 Basic electric circuit for a medium frequency coreless furnace

The development of solid-state frequency multiplying devices enables variable frequency output in the medium frequency range. A frequency converter consists of:

- a rectifier to convert ac current from the mains to dc;
- an inverter to reconvert the dc current to a single-phase medium frequency ac current;
- a bank of tuning capacitors.

Output frequency and voltage are controlled automatically to match the resonant frequency of the furnace circuit, so the need to change capacitors is eliminated.

Further information on the principles of electrical induction melting is given in Appendix 1.

2.2 Energy Consumption in Iron Foundries Melting by Induction

Energy Consumption Guide 48, *Energy consumption in ferrous foundries (second edition)*, shows that UK foundries using only electric furnaces for melting produced some 44% (621,000 tonnes) of the iron castings made in 1998, consuming 1.7 TWh of delivered energy at a total cost of £48 million, i.e. £77 per tonne.

Many foundries use both electrical induction and coke cupolas for melting. The total quantity of iron castings produced from induction melt units is estimated as between 750 - 800,000 tonnes per year.

In recent years there has been a considerable move from cupolas to electrical induction furnaces. Reasons for this include the desire of many small or medium-sized foundries to be able to produce a wider range of cast metals, and the greater ease of meeting environmental limits. While energy costs tend to be higher than for cupola melting, other costs, e.g. labour and raw materials, are frequently much lower.

Fig 6 indicates that, in general, the greater the throughput of iron, the lower the energy cost per tonne of metal melted.

The wide spread of figures can be attributed to the different circumstances of each foundry; they differ not only in size, but also in products, raw materials, processes, shift patterns and so on. Nevertheless, every foundry should check its energy usage, plot it on Fig 6, and question its own procedures if the value appears high.

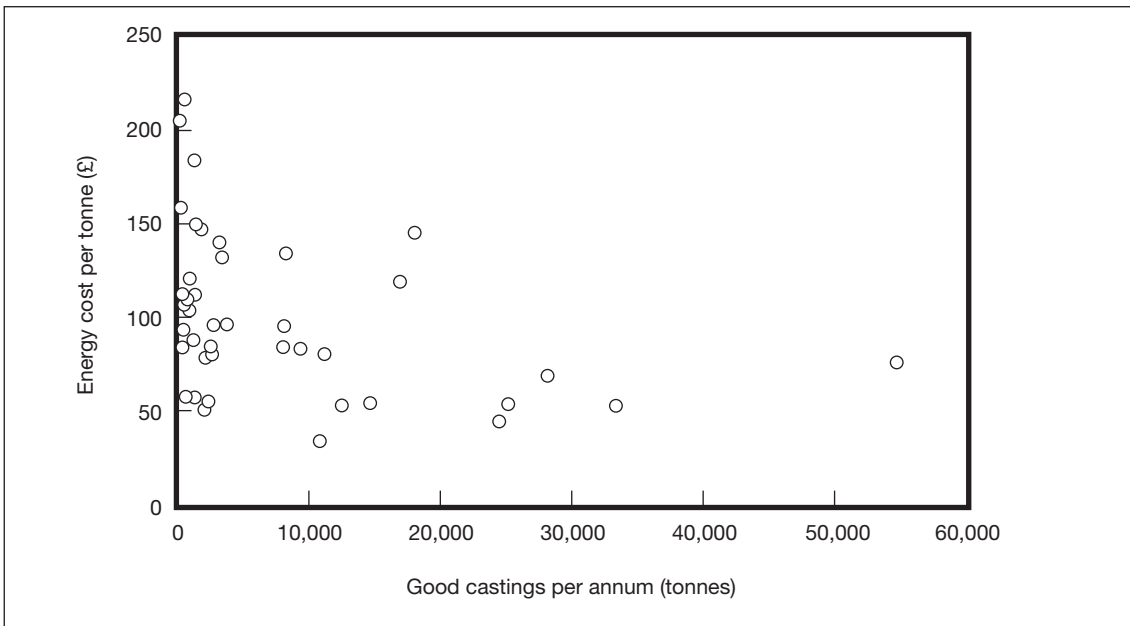

Fig 6 Energy cost of melting vs. throughput

Currently, very few foundries have installed adequate sub-metering to allow the energy usage by individual sections or items of plant to be measured, recorded and controlled. It is, therefore, impossible to arrive at 'industry norms'. Figs 7 and 8 indicate the distribution of energy costs that might be expected in iron foundries, relating to both a large, mechanised plant and also a smaller foundry using chemically-bonded sand respectively.

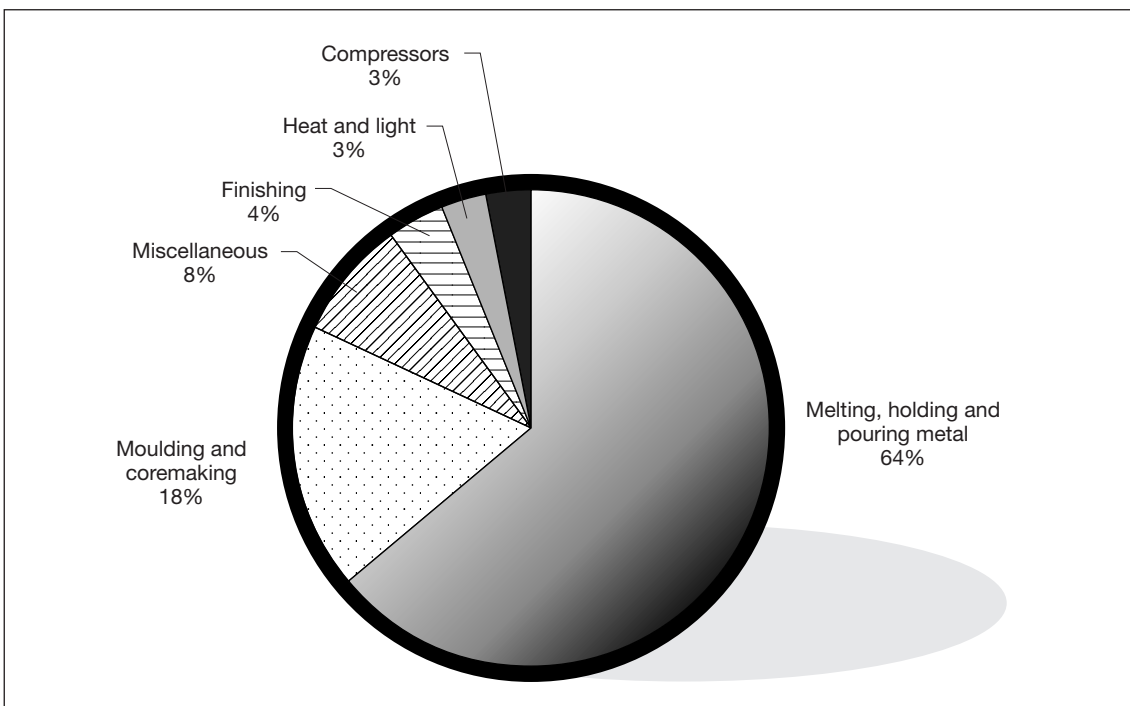

Fig 7 Typical energy usage in a large iron foundry

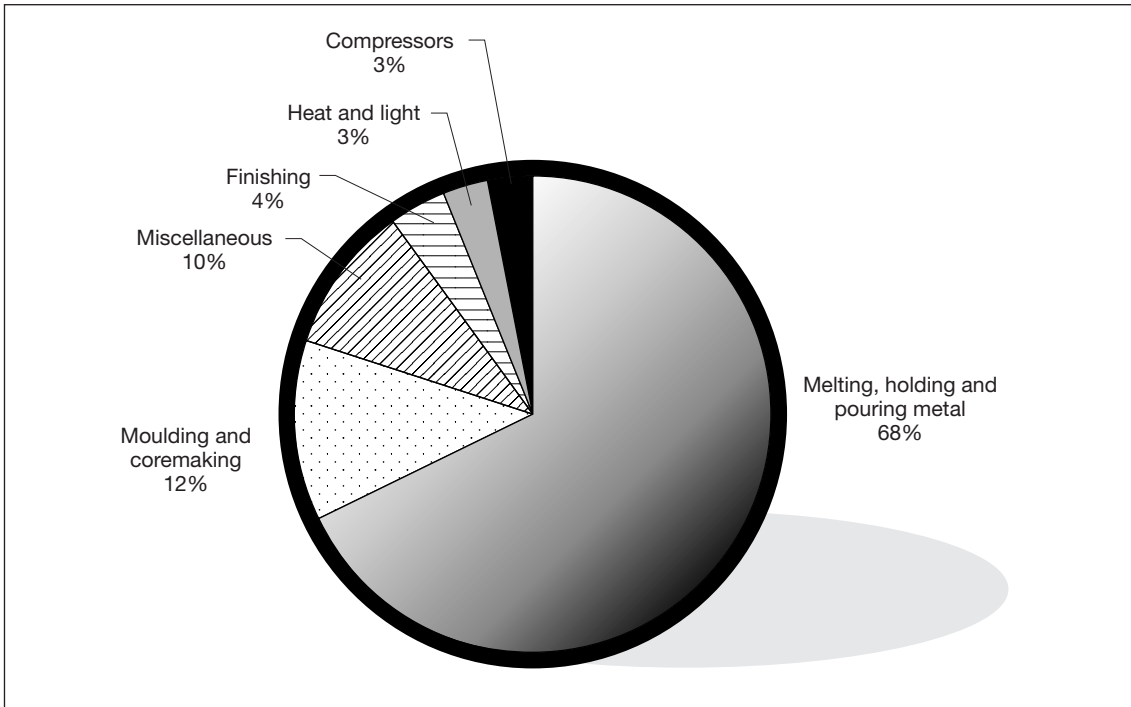

Fig 8 Typical energy usage in a small iron foundry

3. KEY MESSAGES

Achieving efficient operation of coreless induction furnaces depends largely on implementation of good operating practices. It is important that the original specification of furnace requirements is sufficiently detailed to enable the correct selection to be made, and energy efficient operating practices to be developed.

Table 1 lists action points that should be considered when specifying a furnace, and deriving and implementing sound operating practices. All provide useful energy efficiency advice - the more important considerations are marked with a double tick (✓✓). Detailed advice is given in the subsequent sections of this Guide.

Table 1 Key messages - action list

Area	Energy efficient advice	Value
Selection	When planning the purchase of new coreless melting plant, specify to minimise running costs, particularly with regard to energy. Capacity, power density and frequency all have a significant impact on specific energy consumption (SEC).	✓✓
Optimum utilisation	Retain the optimum size of molten heel in a mains frequency coreless furnace. Compared with a 33% heel retention, a 67% heel could typically give a 5% saving in energy usage.	✓
	Arrange melting programmes to reduce the number of cold starts. The refractory lining has a high thermal mass. Melting with a cold furnace can require 10% more energy than melting with a hot start.	✓✓
	At the end of the day, place metals into the hot furnace and close the lid. This allows them to absorb sensible heat during the night, thereby reducing the energy required for the first melt on the following morning.	✓
	Use clean charge materials, which inherently require less energy to melt. If dirty feedstock is to be used, check that savings in metal purchase costs outweigh the hidden, extra melting costs.	✓✓
	When charging furnaces during the melting cycle, carry out the operations as quickly as possible. Avoid protracted delays while the furnace lid is held open or the power turned down. Good charging facilities and good procedures are essential.	✓
Melting and de-slagging	Always melt down with the maximum permissible power input level applied throughout the cycle. The longer it takes to accomplish the melt down, the higher the SEC.	✓
	Carry out de-slagging as quickly as possible.	✓
	Ensure that the furnace lid fits well and is kept closed, except when access to the bath is essential. Furnace lids are important if long holding periods are used.	✓✓
	Develop an appropriate, individual policy regarding slag. Slag build-up and lining erosion due to slag attack will affect SEC.	✓
	Do not raise the temperature of the liquid metal in the furnace more than is absolutely necessary. Unnecessary superheating of metal wastes energy and may introduce metallurgical problems.	✓✓

Table 1 Key messages - action list (*continued*)

Area	Energy efficient advice	Value
Holding	Strictly monitor any delays arising when metal is verified for composition and adjustments made. Efficient organisation of facilities and procedures for analysis and composition adjustment is recommended.	✓✓
	Always minimise the time spent holding metal at temperature.	✓
	Co-ordinate timing with all other foundry activities, particularly in jobbing foundries, so that furnaces containing liquid metal are not kept waiting while ladles or moulds are prepared for pouring. In addition to increasing energy consumption, holding molten iron can adversely affect nucleation if the carbon level of the iron drops.	✓✓
Metering and control	Always meter electricity consumption and relate it to furnace throughput. Use of automatic control, available on modern furnaces, enables the operator to pre-select the amount of energy required for melting or holding, thereby decreasing the possibility of excessive energy input.	✓✓
	Provide either on-load stepless power control or a hold power contactor as an alternative to the traditional off-load tap charger, to improve SEC when operating a tap and charge procedure.	✓
Power factor	Test the capacitors if the furnace is an old installation. A poor power factor can both increase electricity costs and reduce melting rates. Capacitor banks can deteriorate with age.	✓✓
Extraction units	Use efficiently designed extraction facilities and switch them off as soon as melting operations have ceased. Ventilation of fume and dust from coreless melting operations involves power usage in addition to that consumed for melting.	✓
Heat recovery	Consider any practical applications for the waste heat in the furnace cooling water.	✓

4. SELECTION OF NEW CORELESS MELTING PLANT

4.1 General

The specification of furnace requirements is very important and should be considered carefully. As with many electrically powered items, the cost of electricity consumed over a typical 10 - 20 year lifetime can be many times more than the original outlay. Thus, specifying and using an inappropriate induction melt unit can prove to be a false economy.

When a foundry is contemplating the purchase of new or second-hand coreless melting furnaces and preparing an equipment specification, it provides a useful opportunity for giving serious consideration to ways of achieving good energy efficiency and, hence, achieving lowest operating costs. Although energy efficiency is only one of many aspects that have to be taken into account, it deserves to be a priority issue. In the long term, the operating costs are likely to be more important than the initial capital costs.

For example, a new 5-tonne capacity medium frequency melt unit would cost between £500,000 and £800,000 (depending on the complexity, building works and additional power requirements). However, over a 15-year, 'typical' life it would consume in excess of £4 million of electricity (to melt 8,000 tonnes of iron per year at 700 kWh/t and 5 p/kWh). Therefore, specifying, installing and correctly using a suitable, efficient unit will have a significant impact on the total cost of installing and operating an electrical induction unit over its lifetime.

Correct specification involves the following key actions.

1. The first, and often most difficult step, is to establish a realistic estimate of the future requirements for the melting unit, based on various types of metal. An underestimation of the melting capacity required will lead to a restricted castings output. However, excessive melting capacity will require unnecessary capital investment and more floor space, and will offer a less efficient energy utilisation.
2. The next key issue is to decide the quantity of molten metal that will be required and the frequency of delivery, as this has an obvious bearing on the selection of melting rates, capacity and operating requirements of the furnaces. The types of metal to be melted, pouring temperatures, raw materials, and the control, verification and adjustment of composition, all need to be considered in detail. A role for duplexing or requirements for holding should be examined, and the electricity tariff arrangements explored.
3. At this stage, satisfactory charging arrangements, stockyard facilities, safety considerations, de-slagging operations, renewal of furnace linings, and dust and fume control should be considered. Efficient charging methods not only minimise labour requirements but also reduce specific energy usage because the time for which the furnace lid is open is reduced to the minimum.
4. Comprehensive discussions should then take place with furnace manufacturers and electricity supply company representatives to prepare plant specifications that will fulfil the anticipated requirements at optimum capital costs and offer good energy utilisation. If practical, the possibility of using automatic pouring plant, which can be very energy efficient, should also be considered.

Modern medium frequency furnaces powered by solid-state thyristor controlled inverters are now selected for virtually all applications. These units operate at frequencies typically from 250 to 1,000 Hz and are readily capable of melting from a cold start.

4.2 Important Furnace Design Characteristics

4.2.1 Mains vs. Medium Frequency

As furnace capacity increases, the power that can be applied also increases. Figs 9a and 9b show a manufacturer's quoted data for mains and medium frequency furnaces respectively. Medium frequency furnaces rated at 600 - 1000 kW/tonne are typical, but it is unusual to have mains frequency units rated higher than 300 kW/tonne because of the excessive stirring action produced. The wide scatter of results indicates the diverse operational practices employed by foundries and highlights scope for improvement.

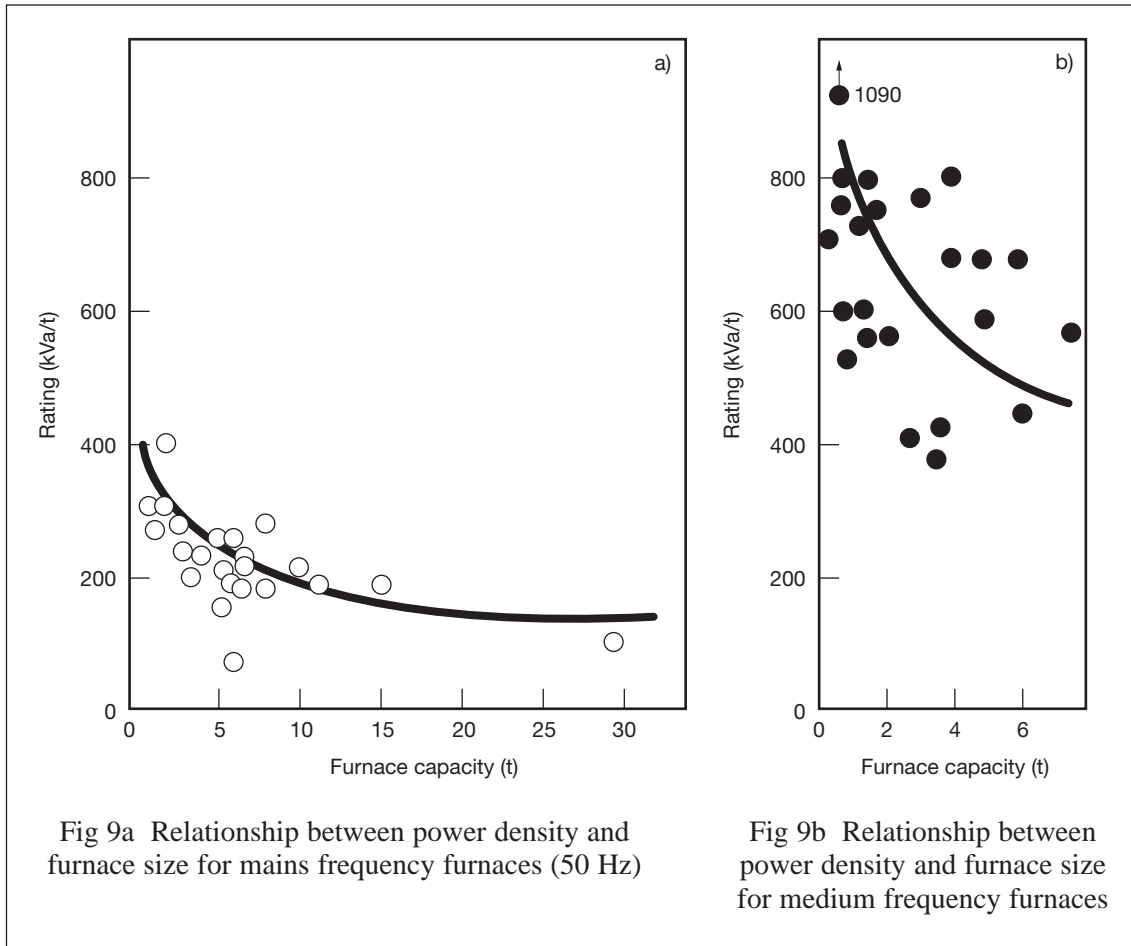

Based on a power factor of 0.9, the industry averages for the power densities developed by mains frequency and medium frequency furnaces are 204 kWh/tonne and 584 kWh/tonne respectively. Because power density generally decreases as furnace capacity increases, and assuming optimum melt conditions, a medium frequency furnace will melt 100% of its crucible capacity in one hour, compared with approximately 40% for a mains frequency unit. Furthermore, the energy consumption of an inverter-powered medium frequency furnace is typically 10 - 20% less than that of a mains frequency unit.

The benefits of a medium frequency power supply for both enhanced melting performance and energy efficiency have been highlighted, but it should be noted that an increase in frequency results in a decrease in the stirring action produced in the molten metal bath. This makes it more difficult to assimilate additions, such as carburisers, into the melt unless sufficient power is applied. The application of intermediate frequencies (150 - 250 Hz) may be of benefit in such cases, as the stirring characteristics will be improved without the need for very high power densities and the consequent risk of lining problems.

4.2.2 Influence of Furnace Capacity and Power Density

Furnace capacity, frequency and power density have a significant influence on melting and holding performance and also on the energy consumption per tonne of metal melted (Figs 10 and 11).

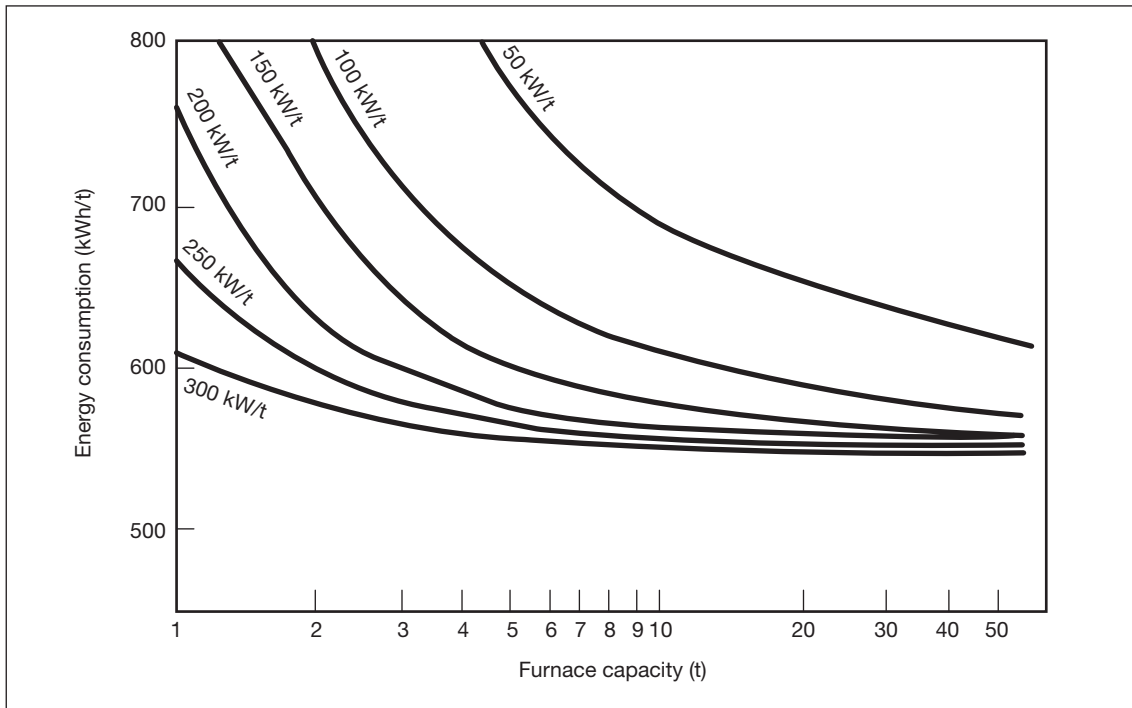

Fig 10 Effect of power density on energy consumption

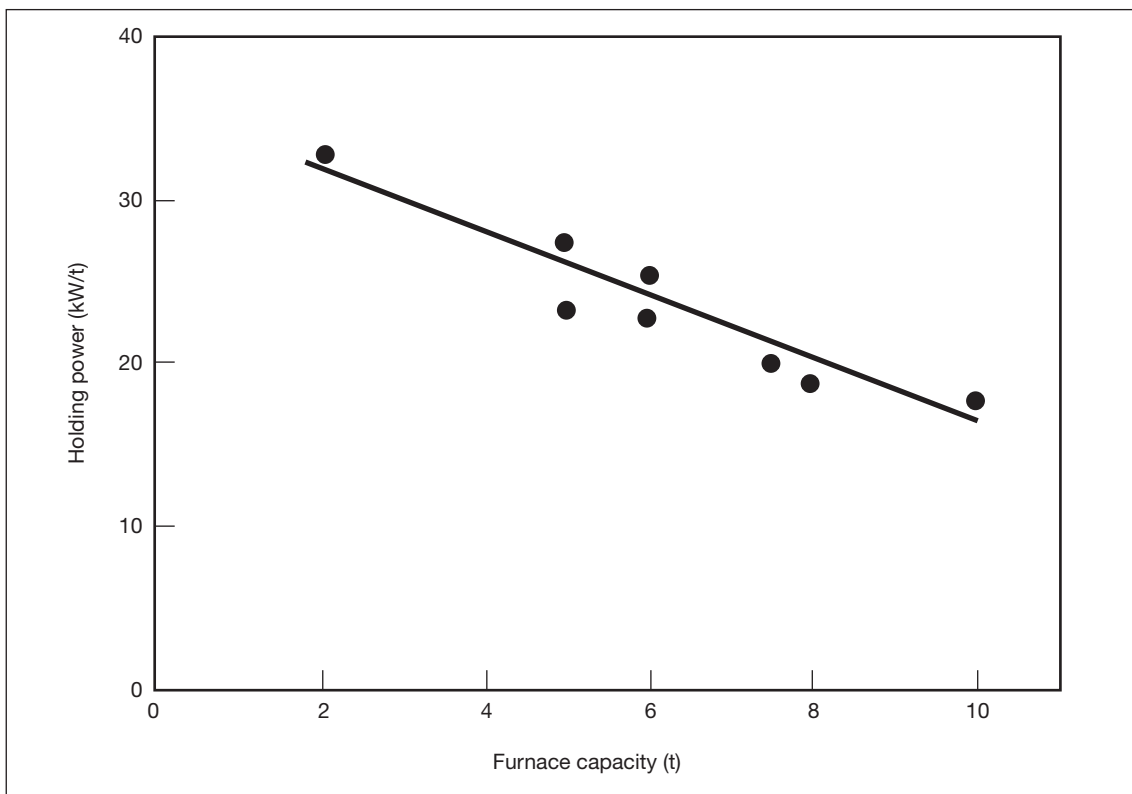

Fig 11 Energy consumption for holding iron in coreless furnaces of various capacities

Power density and the capacity of a particular furnace will influence SEC, whether the furnace is used for melting or holding. However, in both cases, the larger the furnace capacity the lower the SEC.

4.2.3 Automatic Power Control and Monitoring

Many modern furnaces are fitted with control equipment that enables the operator to pre-select the amount of energy required for melting or holding - only this amount is supplied, irrespective of the furnace conditions. The use of such equipment, which either switches off power to the furnaces completely or reduces it to a lower level, clearly decreases the risk of excessive energy consumption and, consequently, reduces the risk of lining erosion due to any oversight by the furnace operator.

Modern furnace plant can be purchased with melt control computers that, in addition to the function described above, can provide other useful information and facilities (see Section 6.4).

4.2.4 Optimising Furnace Design

The Sankey diagram (Fig 12) shows that 20 - 30% of electrical energy supplied to a coreless furnace is absorbed by the cooling water system. There has been considerable effort to improve the efficiency of coil design and refractory lining construction to reduce these losses.

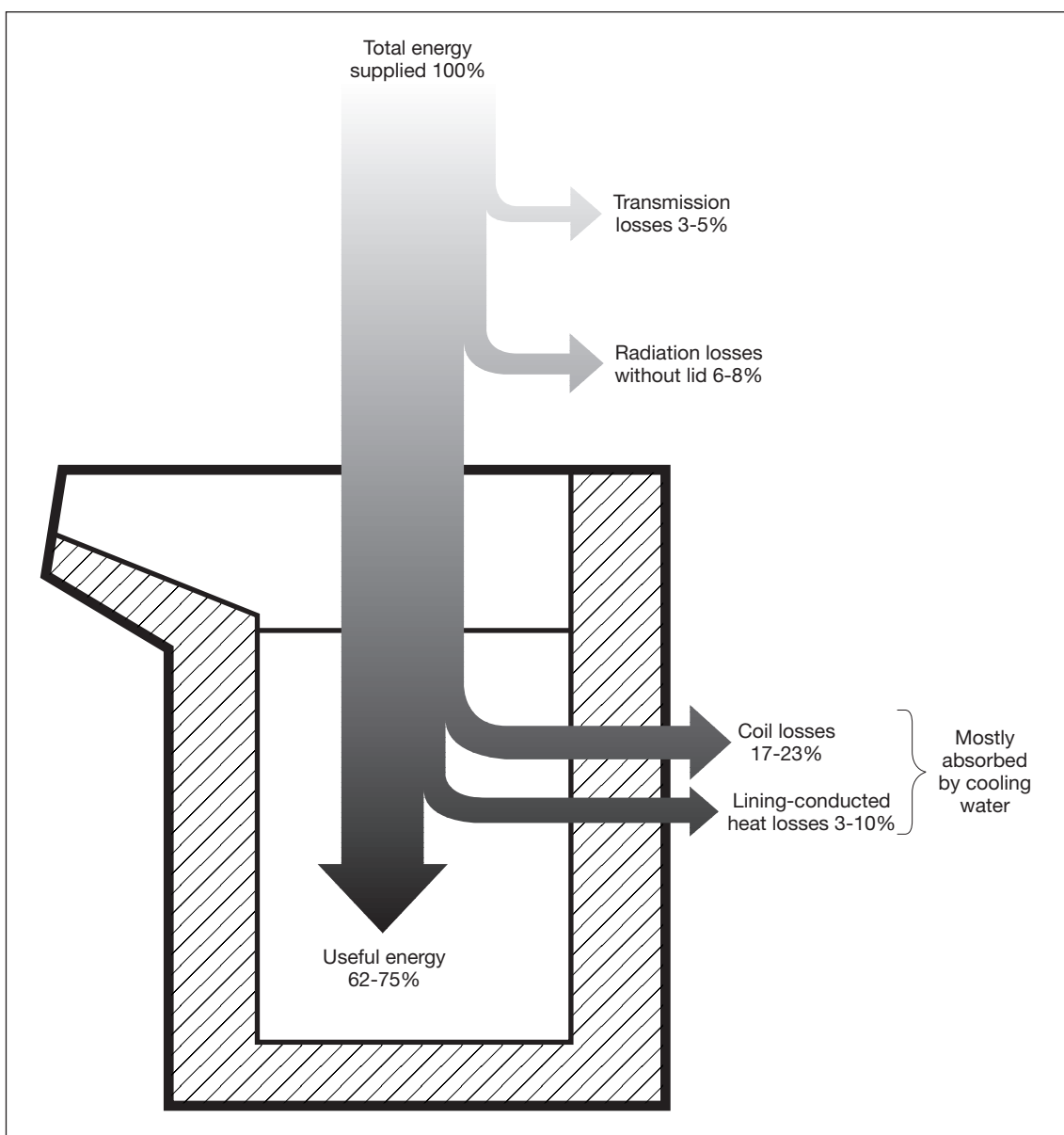

Fig 12 Energy losses in a mains frequency coreless furnace (Sankey diagram)

As the coil and crucible diameters increase, the area of exposed metal surface also increases, along with heat losses through the lid. In addition, the larger the furnace diameter the more difficult it becomes to de-slag, increasing operator discomfort from greater heat exposure. However, the larger the furnace diameter the more readily it can be charged, decreasing the risk of charge bridging or damage to the top of the crucible refractory lining. When considering the 'optimum' crucible there will always be a trade-off between energy efficiency and ease of operation.

A major heat loss to the cooling water system of coreless induction furnaces is via conduction through the refractory lining. This loss is governed largely by the surface area of the bath in contact with the crucible and the dimensions and thermal characteristics of the lining construction. The lining thickness can be used to control heat loss, but, as this dimension also affects the coupling between the charge and the coil, power factor values and electrical efficiency, only limited scope for energy conservation is possible. As a furnace lining campaign proceeds, the refractory wears and there is a closer coupling between the induction coil and the metallic charge. This enables the furnace to draw more power, with a consequent improvement in both melting capability and energy consumption values.

The refractory lining of a coreless furnace has a considerable thermal mass that requires a significant electrical input to bring it to operating temperature each time the furnace is started from cold. Therefore, single-batch melts are less energy efficient than multiple-batch operations. Some foundries back-charge furnaces with cold scrap at the end of a day's melting campaign, so that some heat is transferred to the charge. Other operators adopt a policy of ensuring that the lids are well-fitting and sealed at the finish of melting, thereby retaining the maximum amount of heat before recharging.

Summary

- The first question that should be asked is, 'does the foundry want, or need, induction melting?'
- If the answer is 'yes', then it is important to select a unit that is optimum for the foundry. For this, the foundry operator will need to:
 - establish metal demand and frequency of demand;
 - consider the range of alloys to be produced;
 - assess storage requirements;
 - examine operational issues, e.g. charging, de-slagging;
 - evaluate environmental issues;
 - discuss tariff options with a number of electricity supply companies.

5. CHARGE MATERIALS AND CHARGING OPERATIONS

5.1 Overview

The furnace charging practice adopted by a particular melting plant has a considerable influence on the electrical energy used per tonne of iron melted.

Coreless induction furnaces are usually regarded as ‘dead melting’ units where, effectively, only minimal changes in composition occur during the process. For adequate control of chemical composition (in particular, trace element levels) it is, therefore, essential that charge materials be carefully controlled. The physical properties and chemical composition/condition of the materials, e.g. size, bulk density, cleanliness, freedom from rust, scale, oil and other metallic/non-metallic coatings or attachments, and degree of contamination with residual or trace elements can affect:

- quality of the metal produced;
- production rate;
- volume of slag produced;
- energy consumption;
- refractory lining life;
- safety of both plant and personnel.

5.2 Condition of Charge Metallics

5.2.1 *Cleanliness*

Generally, more energy is required to melt rusty or dirty steel scrap, bales with a light bulk density and cast iron borings, than clean, dry, chunky steel scrap. This is because the former limit the amount of power that can be applied, thereby extending the time required to melt the charge, as shown in Table 2.

Table 2 Effect of rusty scrap charge on energy consumption

Charge materials	Charge weight (kg)	Melt time to 1,500°C (min)	Energy (kWh)	Consumption (kWh/tonne)
Clean steel scrap	250	75	210	840
Rusty steel scrap	200	185	270	1,350
Rusty steel scrap	275	192	335	1,218

During the melting operation the furnace is constantly losing heat, both to the cooling water and by radiation from the shell and the exposed metal surface. Electrical energy has to be expended to replace this heat loss; hence, the longer the melting time the greater the inefficiency.

Dirty or contaminated scrap tends to deposit a slag layer on the furnace refractory. This occurs at, or just below, the liquid metal level in the crucible and restricts the amount of power that is drawn by the furnace. The effective reduction in the internal diameter of the furnace may also make charging more difficult and protracted, again affecting energy efficiency.

Some furnace operators shot-blast all scrap returns before charging, in an attempt to minimise slag accumulations on the furnace wall. However, shot blasting is an expensive process and increases operating costs. To minimise the problems associated with the build-up of slag, many foundries operate at a higher metal temperature than is strictly necessary, or undertake an occasional high temperature melt to reduce the build-up, again increasing energy consumption.

Wet or oily metal must not be charged, unless drying or pre-heating facilities are available, due to the risk of explosions and the potential for injury and/or damage to the furnace and its ancillary equipment.

For further information on the importance of good material selection, see Good Practice Case Study 213, *Demonstrating good practice in medium frequency coreless induction furnaces*, and Future Practice Profile 47, *Quantifying important factors in iron melting in medium frequency coreless induction furnaces*.

5.2.2 Size

Scrap size is particularly important with coreless induction furnaces operating at lower frequency. If the packing density is poor, the melting period is extended and the SEC raised. Low bulk density scrap takes longer to charge, further extending the melting period.

With small, manually charged furnaces, charge metal is normally limited to 300 mm in length, although larger dimensions may be acceptable if care is taken to orientate the pieces on charging. When the furnace is dump-charged from a skip or bucket, it is advisable to restrict the length of any individual piece to one-third of the crucible diameter.

Relatively thin section stock in the form of 'punchings' or off-cuts presents very few problems, but material of low density packing may lead to increased oxidation losses and extended melt times. The use of baled scrap should be avoided in small furnaces and strictly controlled in larger units. Baled scrap often contains moisture and other undesirable contaminants.

Due to fusion of the material, particulate scrap, e.g. borings, can create 'bridging' of the charge above the melt, with consequent power reductions and/or stoppages while the obstruction is dealt with. The use of briquetted borings in electric melting is not recommended due to the severe oxidation that occurs as they enter the melt.

5.2.3 Addition Materials

Carburisers

A wide variety of materials are used in induction furnaces to provide carbon pick-up in molten cast iron. Graphite and petroleum coke are the most popular, the latter being used on commercial grounds whenever technically acceptable.

Where metal turbulence is high, the rate of carbon solution or recovery is not significantly influenced by the size grading of the carburiser. Where metal stirring is low, assimilation is improved by the use of a finer carburiser, although material containing significant quantities of very fine particles should be avoided due to excessive loss.

Metallurgical silicon carbide (containing 63% silicon and 31% carbon) provides a number of benefits. Normally charged early in the melt with the steel scrap, which promotes faster absorption, it acts as a de-oxidiser and is claimed to improve lining life by eliminating or reducing the aggressive oxides in the charged metals. Compared with most other carburisers, the lower sulphur, hydrogen and nitrogen contents can be beneficial.

Alloying Additions

A wide range of metal and ferro-alloy additions are used in cast iron production, either as a charge constituent or for trimming purposes.

5.2.4 Storage

Effective raw material storage is important for optimum performance from the furnace equipment. With small, relatively low output plant the situation is comparatively straightforward, but, nevertheless, requires careful consideration.

- The storage area should be planned to avoid double handling and allow direct discharge from trucks and easy unloading of skips, or other containers, by fork lift or overhead crane.
- Raw materials for melting should be stored under cover in clearly defined areas, or in storage bins, to avoid charge make-up problems.

- Where necessary, day storage facilities should be located adjacent to the furnace plant and, where small furnace and manual charging systems are involved, on the platform itself.
- The number of storage bins and their capacity should allow for uninterrupted charging during the melting shift and compensate for any period when overhead cranes are unavailable.

The effect of inadequate raw material control on casting quality is shown in Table 3.

Table 3 The effect of inadequate raw material control on iron castings quality

Raw material	Examples of lack of control	Immediate effect	Effect on casting quality
Pig iron	Required composition not specified on purchase order Advice note information on chemical composition not used Batches not segregated and identified in the stockyard No occasional checking of composition by the laboratory Batches not used in accordance with composition	Variable or incorrect metal composition	Metal not to specification Metal too hard with chill in free edges Metal too soft Shrinkage-porosity defect
Cast iron scrap	Return scrap and bought scrap not segregated by grade	Charge compositions not correct	Metal not to specification
	Some pieces of scrap too large	Bridging and uneven melting	Variable metal temperature and composition
	Non-ferrous parts containing lead, aluminium etc., not removed from bought scrap Delivery of heavily painted scrap accepted into stockyard Excess of vitreous enamelled scrap in each charge	Contamination of the metal with: - aluminium	Pinhole defects
		- lead	Serious loss of strength Cracking
		- boron	Chill and increased hardness
Gas-works scrap accepted into stock	- antimony	Increased hardness	
	High-sulphur iron	Chilled edges and sections Top-surface blowholes	
Steel scrap	Grade and unwanted contaminants not specified on purchase order Pieces of sulphur-bearing or leaded free-cutting steel Pieces of non-ferrous metal in baled/fragmented scrap Heavily painted scrap Pieces of stainless steel	Contamination of the metal with: - aluminium	Pinhole defects
		- sulphur	Chill and top-surface blowholes
		- lead	Serious loss of strength Cracking
		- chromium	Chill and increased hardness
	Pieces larger than one-third cupola diameter	Bridging and uneven melting	Variable metal temperature and composition
Non-ferrous alloy scrap	Free-cutting copper scrap containing tellurium Nickel/copper alloy scrap containing lead and aluminium, and leaded-bronze inserts	Contamination of the metal with: - tellurium	Chilled sections
		- lead	Serious loss of strength or cracking
		- aluminium	Pinhole defects
Ferro-alloys	Composition and grading requirements not adequately specified on purchase order Failure to check container labels against advice note information Materials not clearly labelled or segregated in the stores	Ferro-alloy pieces too large, not dissolved	Hard-spots on machining
		Incorrect materials used	Metal not to specification
	Materials not kept dry	Moisture pick-up	Pinhole defects
	No laboratory checking of materials against specification, e.g. aluminium in ferrosilicon	Aluminium contamination	
	Variations in sulphur/nitrogen content of carburisers	Variable content of sulphur and variation in response to inoculation treatment	Chill, or poor graphite structures
		Variable content of nitrogen	Fissure defects Variation in tensile strength and hardness

5.3 Furnace Charging Techniques

Whatever the charging practice employed, the primary aim is to restrict the time the furnace lid is open, thus reducing heat loss and improving SEC. Typical heat losses from a coreless furnace are shown in the Sankey diagram (Fig 12, page 14).

A well-fitting furnace lid in the closed position will limit the furnace radiation heat loss to about 1% of the input power. Table 4 illustrates radiated heat losses (kW) from typical coreless furnaces of 6-tonne and 10-tonne capacity.

Table 4 Effectiveness of furnace lids on radiated heat losses

Furnace capacity (tonnes)	Energy loss (kW)			Energy costs (£)	
	Lid open	Lid closed	Difference	Cost/day*	Cost/year*
6	70	9	61	3.05	702
10	130	13	117	5.98	1,346

* Assuming 230 working days/year and 5p/kWh.

Clearly, it is important that furnace lids are fitted, kept closed whenever possible during melting, and maintained in good condition. In the example in Table 4, the annual cost of waste heat would be £700 in the case of the 6-tonne furnace and £1,300 for the 10-tonne unit.

Charge make-up and charging and melting procedures should ensure that the metal is at the correct chemical composition following melt-out and superheating to the required tapping temperature. This eliminates the need for adjusting the bath analysis by the use of 'trimming additions', a practice which results in decreased melting performance in terms of melt rates and energy consumption.

A wide variety of systems may be employed to convey the charge materials from the day bins to the furnace; these generally include a means of making up and weighing the charges. The charging procedures should be designed to prevent damage to the relatively fragile crucible wall and to provide maximum safety for personnel and equipment. The free fall of materials, which may strike the furnace wall, must be avoided.

Movement of the molten metal in a bath accentuates the hazards associated with the charging of rusty, damp or oily materials onto a molten heel of metal, especially when power is applied to the furnace. Controlled charging can be of some benefit, particularly if a layer of dry solid material is charged first to provide a surface on which the less suitable scrap can lie and be pre-heated.

Bridging of the charges in the furnace must be avoided. The addition of excessive amounts of charge to a molten bath can result in the upper part of the charge bridging across the furnace and losing thermal contact with the pool of molten metal below. This results in excessive superheating and potential damage to the lining.

Various charging methods are employed on coreless furnaces.

- **Hand charging** is the simplest system. It is relatively slow and the furnace lid is open for a significant time, resulting in considerable heat loss.
- **Direct magnet charging** can also be a relatively slow operation; again, the furnace lid is swung open and heat losses sustained during furnace loading.

- **Vibratory chute charging** machines are installed on many furnaces, offering a more efficient method (Fig 13).

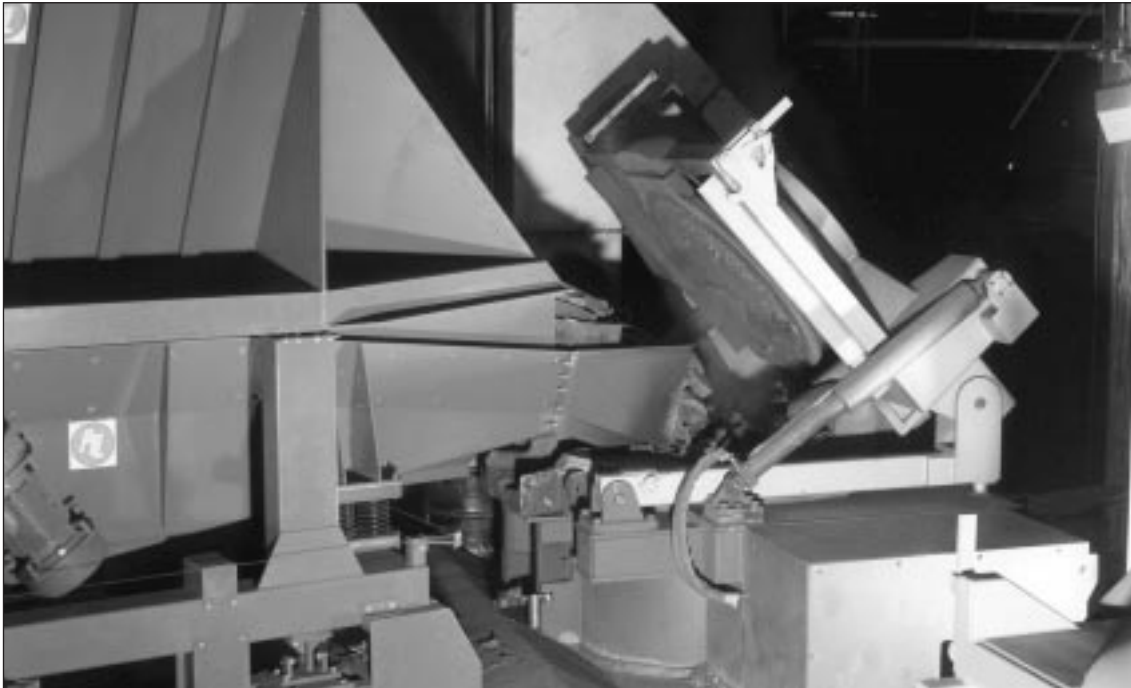

Fig 13 Vibratory charging machine

- **Drop bottom charging** buckets provide a very rapid method of charging and, therefore, minimise heat losses. However, a multiple bucket system may be necessary, which is both costly and disadvantageous if space is limited.

It is now normal practice for coreless furnaces in excess of 4-tonne capacity to be mounted on load cells, providing the operator with a digital indicator showing how much metal is in the furnace. When interfaced with a central computer this provides an accurate record of metal melted. The equipment is also beneficial when having to subsequently ‘treat’ specific amounts of molten iron from the furnace, e.g. inoculation, ‘nodularisation’, alloying, etc.

It has been estimated (Good Practice Case Study 213) that satisfactory charging methods and the use of clean, dry and dense charge materials can result in a saving of 10 kWh/tonne of metal melted. Development work carried out on a one-tonne capacity medium frequency (1,000 Hz) coreless induction furnace identified the following:

- Energy consumption is significantly increased by incorrect charging practices. The worst practice is to charge a small amount and wait for melting to occur before adding further material. The best practice is to add charge to the level of the top of the power coil and to frequently top up as the charge sinks down. The energy consumption difference between these practices was about 100 kWh/tonne.
- Bulk density charges greater than 1,000 kg/m³ give a lower energy consumption than charge materials with low bulk densities of around 500 kg/m³. The energy for melting ‘difficult’ charges (e.g. borings) can be reduced by the addition of other selected charge materials, e.g. heavy scrap.

For full details of the findings, see Future Practice Profile 47, *Quantifying important factors in iron melting in medium frequency coreless induction furnaces*.

Summary

- Ensure only clean, dry scrap of the correct size is charged.
- Limit the use of baled steel scrap and loose borings.
- Store all materials in a dry, well-ordered environment.
- Charge materials carefully to avoid damage to furnace lining.
- Do not charge briquetted borings.
- Avoid bridging of the materials charged.
- Close the furnace lid once charging is completed.

6. FURNACE OPERATION AND CONTROL

6.1 Overview

The operation and control of a coreless furnace is extremely important in relation to the SEC of the melting plant concerned. The ideal situation is rapid melting of the charge, quick superheating to the tapping temperature and then efficient distribution of the liquid metal into pouring ladles or a holding furnace. Unfortunately, the melting department does not operate in isolation but is necessarily integrated with other production areas. Delays and problems in any of these areas affect the melting department. Extended holding and unnecessary superheating inevitably lead to an increased energy usage.

The melting of metal in a cold furnace requires more energy than when a hot furnace is in operation. Hence, a saving in overall consumption will be achieved if the number of cold-start melts can be reduced by modification to the production programme.

The design of modern coreless induction furnaces allows melting control through an on-off button arrangement and power input control. However, it is important that furnace operators remain vigilant. An inadequately supervised furnace may result in excessive metal temperature, with adverse effects on energy consumption and furnace lining life.

6.2 Efficient Melt Scheduling

For effective furnace operation and maximum energy efficiency it is vital to balance the demand for, and the supply of, molten iron. While mains frequency furnaces generally operate with a molten heel, medium frequency units may be completely drained before re-charging, resulting in thermal cycling of the refractory lining. To maximise lining life and minimise energy consumption, medium frequency furnaces should be re-charged and power applied immediately following tapping. The furnace should be maintained full during melting and the tapping time be minimised to maximise energy efficiency.

6.3 Metering Energy Usage

When specifying furnaces it is important to provide for electricity monitoring. In the past, many electric melting plants were installed without meters, so the foundry concerned had no proper means of monitoring energy consumption. Control equipment of the type fitted to modern furnaces allows the operator to select the energy to be delivered at various stages of the melting operation.

In the case of coreless furnaces not fitted with any monitoring capability, the introduction of basic monitoring has the potential to reduce energy consumption by at least 10%. This form of metering does not have to be expensive to install and operate. New Practice Case Study 105, *Efficiency meter provides savings for an induction melting foundry*, describes a coil efficiency meter developed by EA Technology. For furnaces up to 1 MW, the equipment provides instantaneous measurements of input power and coil current, and calculates and displays cost efficiency, total kWh used during the melt and SEC (kWh/tonne of metal melted). The total cost was £2,500 (1996 price). When employed in an aluminium foundry, annual energy savings of 136,000 kWh were achieved, worth almost £7,000, giving a payback of just over four months.

6.4 Computer Control of Furnace Operation

Most furnace suppliers now offer computer-based data analysis and display systems to control and monitor the performance of coreless furnaces and assist in efficient furnace operation. These

computer-based monitoring systems generally provide data displays on a PC screen in graphical and tabular form. Programmable logic controllers transmit data to the computer software and this is then presented to the user in various modules. The data can be stored, tabulated, or graphically displayed, as required (Figs 14, 15 and 16). The detailed information and status situations that can be displayed includes:

- weight and temperature of the metal;
- power input to the furnace;
- water temperatures in the cooling circuits;
- condition of the furnace lining;
- sintering progress and cold-start operations;
- alarms;
- charging status;
- production data;
- kWh consumed for individual furnaces;
- maintenance parameters - critical temperatures, lining condition.

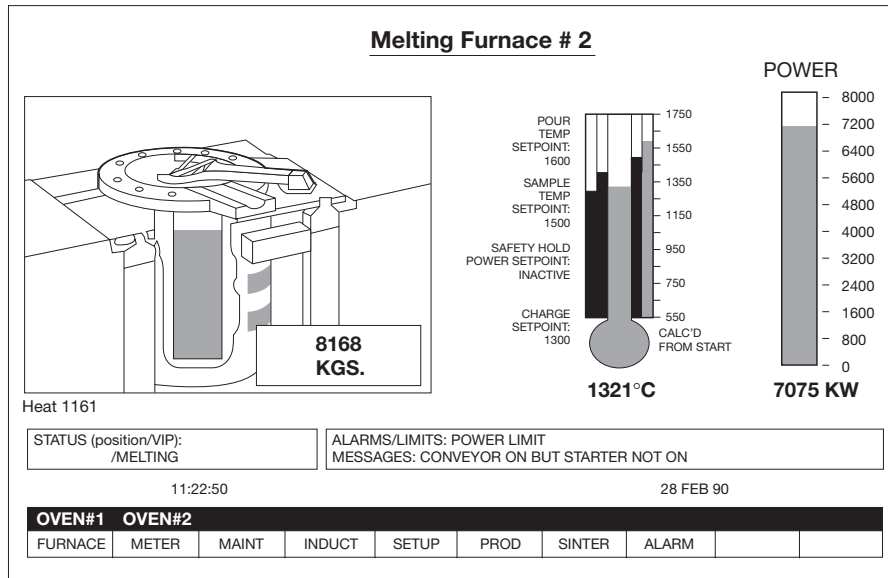

Fig 14 Furnace status screen

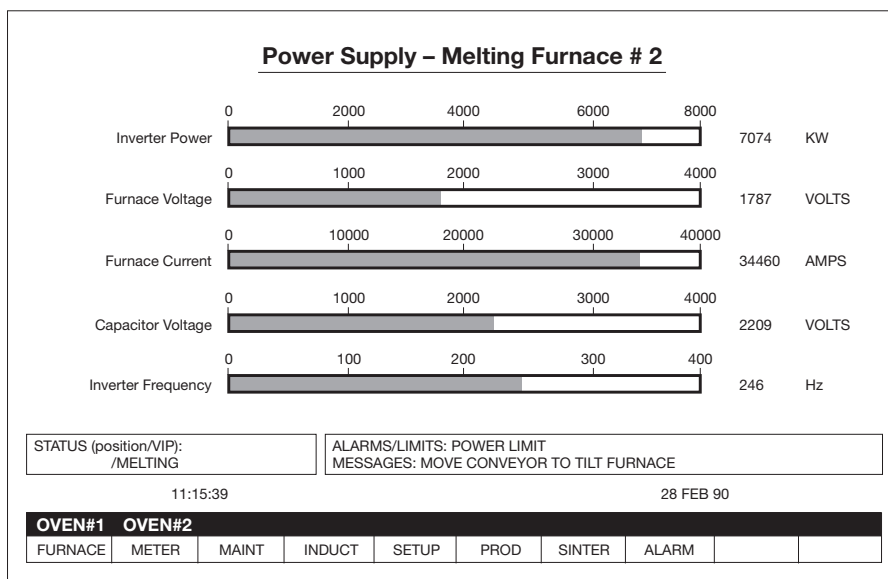

Fig 15 Power supply screen

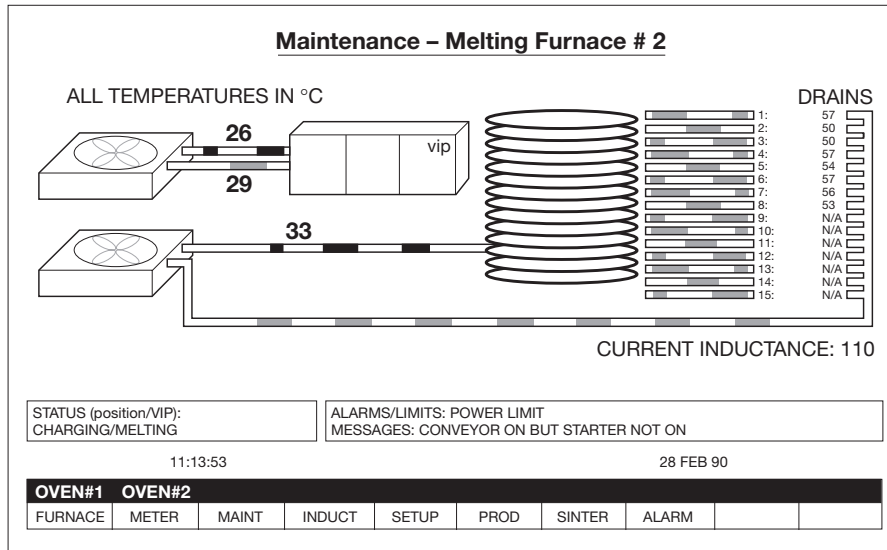

Fig 16 Cooling water temperature screen

6.5 Control of Chemical Composition

An induction furnace provides an ideal vehicle for adjustment of composition to obtain the specification required, before metal is poured into moulds. It is necessary to take a sample from the crucible and either to carry out a test on the platform, such as carbon equivalent evaluation, chill tests etc., or to provide a spectrographic analysis of a chill-cast coin sample. If necessary, the composition of the metal in the furnace can be modified by making appropriate additions. Carbon and, to a lesser extent, silicon are the elements which most commonly require adjustment.

It is essential that analysis and any subsequent adjustment of composition is carried out with the minimum delay; holding metal at temperature for any significant time will greatly increase specific energy usage. To conserve heat and maximise thermal efficiency, the furnace lid should be in place at all times, except when charging, trimming, sampling, de-slagging or pouring.

Where trimming additions are necessary, especially where carburisers are involved, they should be assimilated into the melt, preferably without prolonging the melt cycle. Effectively, this means that they should be taken into solution during the period between sampling (following melt-out) and the achievement of the required superheating/tapping temperature - a time interval in the order of five minutes. For maximum recovery, trimming additions must only be made to a clean, metal bath surface.

6.6 Temperature Control

Clearly, the melting department does not operate in isolation and it is important that the metal reaches the required tapping temperature at the right time. If the moulding department is not in a position to receive it, the metal will have to be held at temperature with a consequent increase in the overall energy used per tonne of castings produced. Co-operation between production control and the melting and moulding departments is essential to minimise electricity usage.

Frequently, furnace operators allow the metal to overshoot the required temperature. This unnecessary superheating uses extra energy for no useful purpose and may result in poor quality metal. At times, the molten iron is deliberately superheated to accommodate inadequacies and heat losses in the downstream distribution and handling activities. The subsequent distribution of metal should be examined to see if improvements to procedures and facilities could be made to enable a safe reduction in tapping temperatures.

For further information see Good Practice Guide 63, *Metal distribution and handling in iron foundries*.

6.7 Slag Removal

Removing slag from the furnace at the end of melt-out is an arduous, hot, unpleasant task that is usually carried out manually by the use of slag rakes and spoons. Larger furnaces (typically over 5-tonne capacity) may have mechanical slag grabs to facilitate removal, and/or back-tilting may be employed (Fig 17).

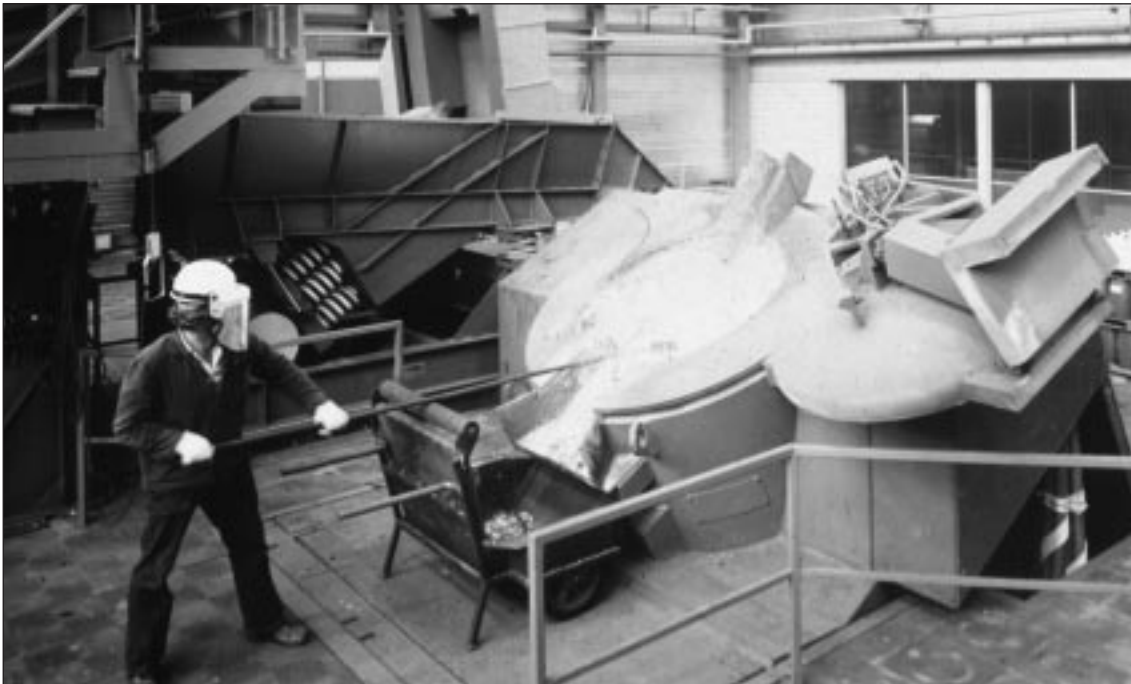

Fig 17 Back-tilting facility for de-slagging

SEC and furnace output per hour can be significantly affected by the efficiency of the slag removal operations. Prompt removal of slag reduces the time that the furnace lid has to be kept open and the associated radiant heat losses. If slag is allowed to build up on the furnace lining, it can also affect the electrical efficiency of the furnace.

Slag build-up is usually related to the condition of the charge materials (clean scrap produces least slag). Some foundries shot-blast return scrap to reduce the production of slag, while others sometimes employ a superheated melt: both options use extra electrical energy.

6.8 Holding Molten Iron

Regardless of how efficiently the metallic charge is melted, the SEC of a melting plant will be considerably increased if the molten iron has to be held for an extended period prior to distribution. The following actions will improve energy efficiency:

- reduce the need for trimming additions;
- tap the furnace as soon as is practicable, once the molten iron has reached the required temperature;
- eliminate unnecessary superheating of the metal and the need for subsequent cooling;
- ensure effective metal distribution;
- minimise plant breakdowns by implementing a planned maintenance schedule.

Summary

- Balance metal supply and demand.
- Meter furnace energy consumption to determine SEC.
- Avoid slag build-up on the furnace walls.
- Remove slag on the metal surface quickly to minimise temperature losses.
- Optimise metal sampling and testing procedures to maintain furnace efficiency.
- Avoid unnecessary superheating of the molten iron.
- Keep the furnace lid closed, other than when charging, de-slagging, sampling and pouring.

7. FURNACE LINING PRACTICE

7.1 Overview

The purpose of the lining is to contain the metal during melting, and electrically and thermally insulate it from the remainder of the furnace, in particular the water-cooled induction coil.

In most furnaces, e.g. cupolas or arc furnaces, a thick refractory lining may be installed to reduce heat losses and provide adequate protection against metal breakout. In the coreless furnace, a relatively thin lining is required for both good electrical coupling with the charge material and high efficiency. To achieve this, the lining integrity must not be compromised by decisions on material selection, lining installation and operating procedures.

A proportion of the heat lost by molten metal in a coreless furnace is by conduction through the furnace lining. Heat is removed either by the cooling water circulating through the induction coil or as radiation from the outer shell of the furnace. The energy lost in this way can amount to between 20 and 35% of the total input to the furnace. Losses are governed by the surface area of the bath of molten metal that is in contact with the lining, as well as lining dimensions and thermal characteristics.

While a thicker lining reduces heat transmission, it adversely affects the coupling between the metallic charge and the coil, reducing electrical efficiency. Consequently, opportunities for improvement in this direction are somewhat limited.

7.2 Coil Protection

The majority of coreless induction furnace coils are electrically insulated to reduce the risk of short circuits between the coil turns.

A 3 - 8 mm refractory coil screed (mica, ceramic fibre or paper/felt) is usually incorporated in the lining construction between the coil and the main refractory. This protects the coil from molten metal damage in the event of a lining failure and forms a slip plane to facilitate movement of the lining during thermal cycling.

7.3 Crucible Material

The choice of the correct lining material for iron melting furnaces is often difficult; factors that need consideration include the alloys melted, melting practice and continuous/batch operation.

Of the three major refractory oxides employed for crucible linings (silica, alumina and magnesia) silica-based refractory material - quartz or quartzite with a boric acid (or oxide) bonding agent - is most commonly used in the iron foundry industry.

The refractory crucible may be installed conventionally by hand ramming, direct/indirect vibration or by employing either consumable, or re-usable, formers. Once a new lining has been installed it must be heated to activate the bond and frit the refractory mass together to form a metal-tight crucible. The fritting procedure should always be carried out in accordance with the supplier's recommendations. Typically, the furnace should be filled with dense, clean scrap prior to applying power. Once melting commences, additional scrap must be added to keep the furnace full. Power levels should be adjusted, if necessary, to ensure that excessive turbulence is avoided. Usually, fritting is carried out by holding metal for one hour at 20 - 50°C above the normal operating temperature.

7.4 Lining Performance

The refractory lining erodes away during its operational life and, as it becomes thinner, there is a closer coupling between the metallic charge and the induction coil, enabling the furnace to

draw higher power with a consequent improvement in both the melting rate and the SEC. The following data (Table 5) for a 3-tonne coreless furnace rated at 700 kW illustrates the point.

Table 5 Effect of lining performance

Campaign	Power input (kW)	Energy consumption (kWh/t)
New lining	615	656
Operation (1 week)	650	622
Operation (3 weeks)	750	598

7.5 Lining Removal

Currently, most furnace linings, with the exception of those for smaller capacity units, are installed using vibration equipment and removed using conventional pneumatic or electrically-powered chisels. Such techniques, although generally satisfactory, are environmentally undesirable due to dust generation and the necessity for the operator to remain in the immediate vicinity during removal. They remain relatively time-consuming and labour-intensive operations, in spite of improvements in vibration techniques and equipment.

To improve this situation, several solutions have been proposed, and adopted to some extent. These include: the provision of custom-built dust collection systems at the crucible mouth; the development of specialised lining wrecking machinery; the use of pre-formed crucibles; and lining push-out devices (Fig 18).

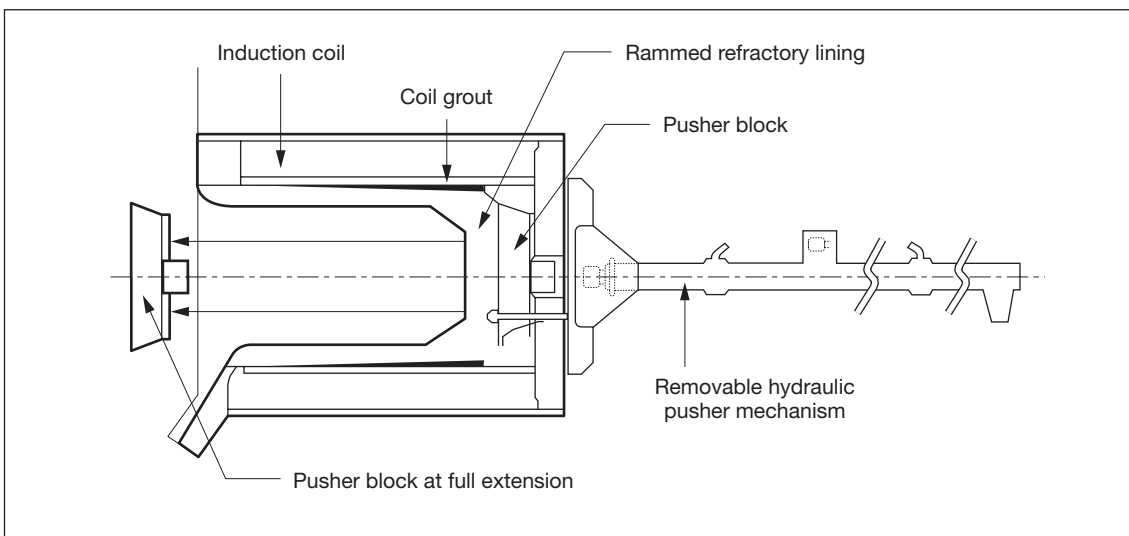

Fig 18 Lining push-out arrangement

In the last decade, pre-formed crucibles have been offered by a number of suppliers as an alternative (Fig 19). The crucible is supplied ready to use, the thickness of its side-wall accounting for about 80% of the total lining thickness. The remaining 20% is taken up by the back-fill material, which is vibrated into position once the pre-formed crucible has been positioned and centralised on a conventionally prepared base. The volume of loose granular refractory required is much reduced, so there is less of a dust problem. Furthermore, since the back-fill is usually an alumina-based material, the silicosis hazard is further reduced.

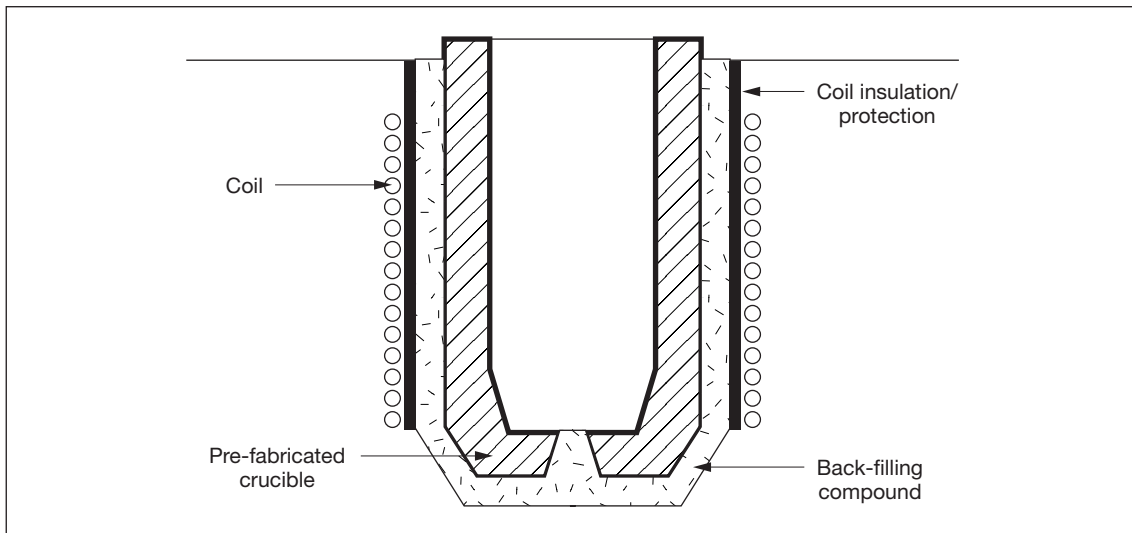

Fig 19 Pre-formed crucible

Summary

- Adopt good lining installation practice.
- Ensure a satisfactory slip plane to allow for lining movement during heating/cooling cycles.
- Select the correct lining material.
- Consider the use of pre-formed linings.
- Monitor lining performance.
- Be aware of the environmental problems associated with the installation and removal of silica linings.

8. ENERGY MANAGEMENT

8.1 Overview

The melting department is an area of the foundry where energy efficiency is most important and where opportunities exist for making good savings. It is the major consumer of energy in most ferrous foundries - usually accounting for more than 50% of the foundry's total energy usage. Based on findings from Energy Consumption Guide 48, the average SEC per tonne of metal melted from coreless induction furnaces is estimated at 718 kWh, compared with a theoretical requirement of approximately 500 kWh.

Increasing energy costs, heightened pressure for energy conservation and existing (and possible future) environmental legislation ensure that energy efficiency will continue to receive attention, and that the melting area will be a focal point. If furnace efficiencies are to be improved, it is a pre-requisite that accurate recording of both electricity use and charge material consumption is undertaken.

8.2 Factors Influencing Output and Energy Consumption

Furnace design can have a major impact on the output and energy consumption of coreless induction furnaces (see Section 4.2.) However, energy consumption is also strongly influenced by the manner in which the equipment is used. The diverse operating practices employed in iron foundries result in significant variations in energy consumption.

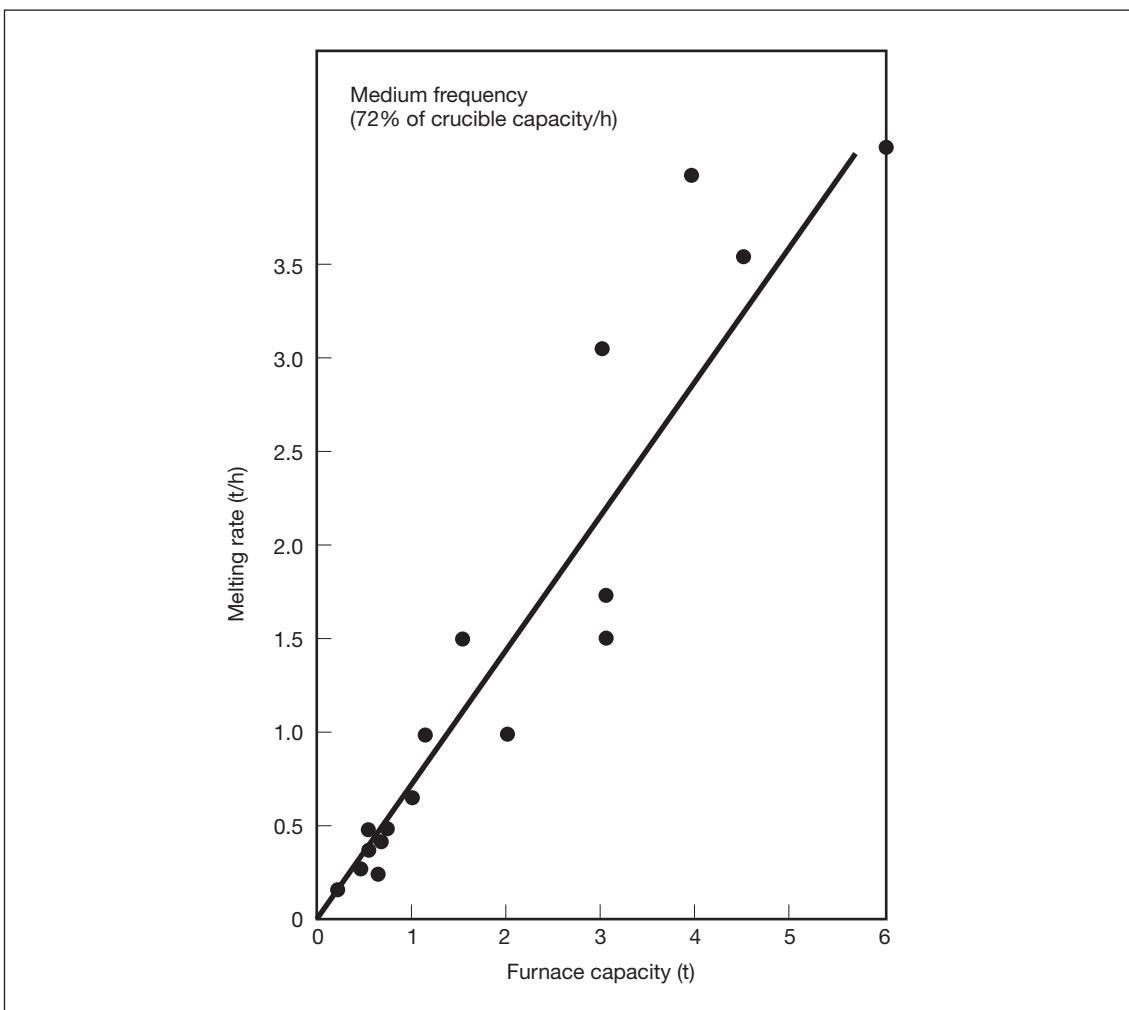

Fig 20 Actual melting rates in medium frequency furnaces

Manufacturers usually quote energy consumption data and melting rate performance for coreless furnaces operated under optimum conditions, i.e. at 100% utilisation, with a hot furnace lining and good quality charge materials. Although these are the only conditions under which the furnace performance can be assessed, they are rarely the conditions under which the furnace is operated. When melting schemes are considered, the practical utilisation factor needs to be taken into account. The actual melting rate achieved is, on average, 72% of the rated output for medium frequency furnaces (Fig 20).

The additional capacity and power rating specified to cater for the lower utilisation expected in practice will result in increased capital expenditure and running costs; therefore, excessive allowances should be avoided.

Energy consumption will increase when furnaces are operated below their optimum or design performance level. Table 6 shows actual furnace performance.

Table 6 Energy consumption in coreless induction furnaces under optimum and practical operating conditions

Furnace capacity (tonnes)	Power (kW)	Energy consumption (kWh/tonne)	
		100% use	Production average
2	700	580	700
3	700	618	760
5	800	590	718
5	1500	620	700
6	1500	625	650
10	1800	571	762

The heat losses from coreless furnaces are proportional to the time metal is held at temperature; therefore, energy consumption is directly influenced by furnace utilisation. As heat losses are dependent on furnace size, it is particularly important that furnaces of small and medium capacity should be operated with a high utilisation factor.

If coreless furnaces are operated on a tap and charge basis, whereby the power to the furnace is switched off, or reduced, then the effective melting capability of the furnace installation will be lowered and the SEC raised. Fig 21 illustrates the influence of both tapping and dead-time on the efficiency of coreless furnaces.

Any factor that causes the furnace to be operated at less than full capacity, by restricting power input levels or causing furnace power to be switched off, will adversely affect energy consumption values. Due consideration should be given to:

- furnace tapping time and frequency;
- molten heel practice (if employed);
- efficiency of the de-slagging operation;
- condition of the charge materials;
- charge handling;
- use of furnace lids;
- compositional adjustments (trimming);
- unnecessary superheating;
- balancing metal supply and demand.

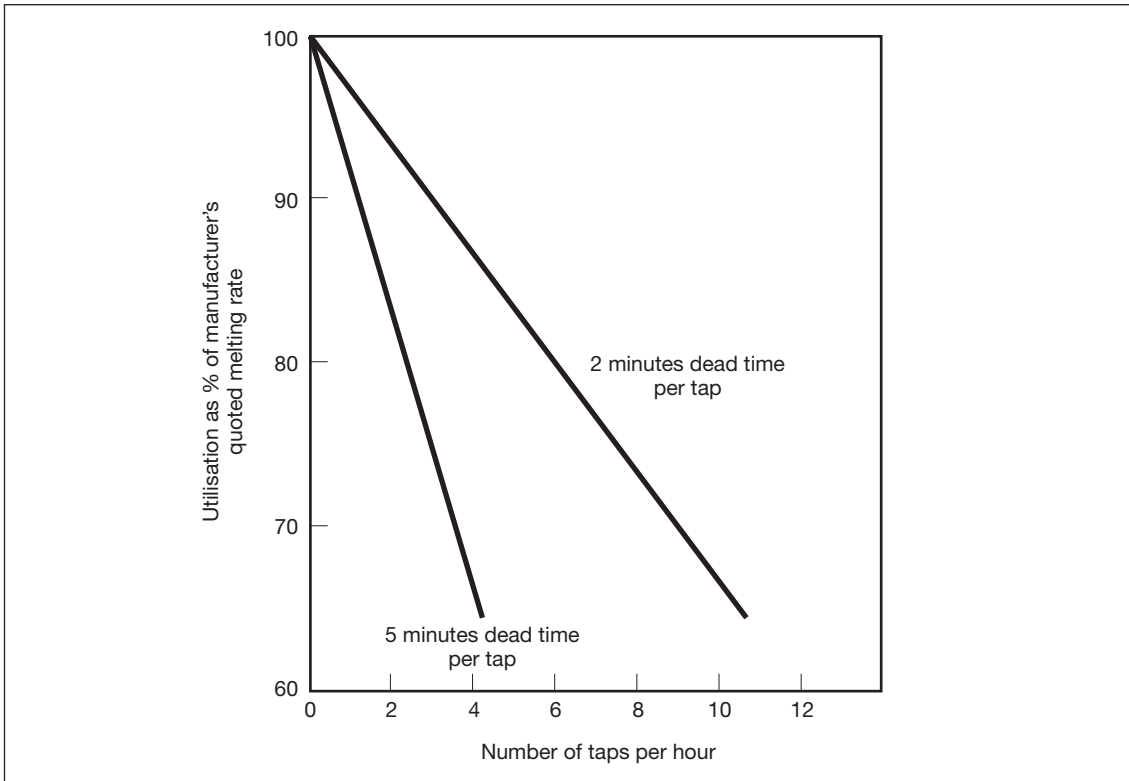

Fig 21 Influence of tapping frequency on melting performance

8.3 Electricity Charges

While the straightforward measurement of energy consumption (kWh used per tonne of metal melted) is important, the cost of electricity varies with the time of day and the season, so the cost per unit is also vital. There may be maximum demand penalties at particular peak hours, so, whenever possible, it is preferable to arrange working procedures and operating schedules so that the furnaces are not drawing full power during peak periods.

The tariff arrangements for electricity charges are quite complicated and companies operating coreless furnace installations are advised to consult their electricity supply company to discuss the details of the tariff structures. The power suppliers are interested in managing the peak demands on their networks; they offer inducements and set penalties to encourage industrial consumers to moderate consumption during periods of high general demand.

Power generation and distribution facilities can also be overloaded when the weather turns particularly severe and unusually low temperatures are experienced. To help in the management of the power network, industrial users may be invited to negotiate favourable ('normal') energy prices, on condition that, having received appropriate notice, power usage may be curtailed during these abnormal periods. Clearly, before agreeing to a tariff arrangement of this type, the foundry concerned must carefully evaluate the financial benefits and other consequences of having to honour such commitments.

Induction furnace installations represent the largest individual electrical load in most foundries. These units must be effectively controlled to minimise the maximum demand charges. The installation of maximum demand controllers is recommended for all foundries with electric melting facilities.

8.4 Power Factor

The power factor is also important when operating induction furnaces. Foundries operating old equipment, where power factor correction may have deteriorated, will experience an increased melting cost and, possibly, reduced output. If the power factor for the plant as a whole is lower than 0.9, seeking expert advice to determine the most cost-effective remedial action is recommended.

8.5 Casting Yield

Another important factor when considering energy management is the yield performance of the foundry. Yield is the percentage ratio of good castings to metal charged. A good yield performance means that less metal has to be melted to produce a given quantity of good castings, i.e. less electricity is consumed on the melting plant.

Example

For every 100 tonnes of good castings produced at 60% yield, about 167 tonnes of metal must be melted. If a foundry were to improve its yield to 65%, only 154 tonnes of molten metal would be needed, saving 13 tonnes of metal melted. With an SEC of 650 kWh/tonne, this would result in savings of 84.5 kWh/tonne of good castings, reducing melting costs by £4.23/tonne (at 5 p/kWh).

Good Practice Guide 17, *Achieving high yields in iron foundries*, contains further information.

Summary

- Assess the benefits of medium frequency coreless induction furnaces.
- Ensure the most favourable electricity charges apply.
- Consider off-peak melting.
- Monitor and control energy consumption.
- Seek expert advice if power factor falls below 0.9.
- Regularly assess refractory wear.
- Minimise the power-off periods.
- Maintain the furnace full in order to draw maximum power.
- Maximise the application of furnace lids.
- Maximise casting yield.

9. ENVIRONMENTAL CONSIDERATIONS

To achieve the objective set down in the Environmental Protection Act 1990, the Environment Agency has issued Guidance Note PG2/3(96) July 1996 which relates to emissions from electric furnaces.

In addition to controlling emissions to the general environment, under the COSHH (Control of Substances Hazardous to Health) regulations the foundry has a duty to ensure that emissions from the furnace do not give rise to excessive levels of pollutants in the internal atmosphere. The principal pollutants from melting of cast iron are lead, dust, quartz and possibly zinc. If any of the exposure levels are exceeded, the foundry will have to fit localised extraction, in which case the concentration of the particulate emission must not exceed 20 mg/m³, as specified in the Guidance Note.

The size and energy requirement of ventilation fans depends substantially on the design of the hoods, enclosure, baffles, etc., that are provided. A well-designed extraction system will be capable of providing effective environmental control using the minimum power. The power requirement for the containment of emissions **at below 100 mg/m³** is about 10 kW for a 7-tonne furnace, whereas power for containment down to 20 mg/m³ is approximately 60 kW.

Emissions from induction furnaces consist of two categories: those emanating from the charge materials and those generated by chemical reactions on the surface of the molten metal. Most originate from the former and comprise:

- rust on the metallic charge;
- dirt adhering to the charge materials;
- various substances (e.g. paint, grease, soot and chemical deposits) coating the scrap, acquired during the former service of the scrap component;
- moulding materials adhering to return scrap;
- cutting oils on steel borings and scrap;
- zinc plating or small die cast items still attached to the scrap;
- carbon and other powder additions made to the metal in the crucible;
- steel and iron scrap that contains non-ferrous alloys.

10. WASTE HEAT UTILISATION

10.1 General

A significant proportion of the electrical energy that is supplied to an induction melting furnace is converted into waste heat. The quantities of heat will vary according to the type of furnace, the temperatures involved and the operating practice. Heat arises in the transformers and the bus-bars but far greater quantities are involved at the furnace, with most heat lost via the water-cooling facility. About 20 - 30% of the total energy input to the plant is dissipated through the cooling water. The furnace cooling circuit not only deals with the electrical losses in the induction coil, but also protects the coil from heat that is conducted through the furnace lining from the hot metal in the crucible. When the furnace lid is closed, the direct radiation losses from the furnace body are about 1% of total input and it would be impractical to try to capture and re-use this heat. However, in some installations the heat in the furnace cooling water has been used for space-heating, heating shower water and drying raw materials.

A foundry that is contemplating making use of heat from the cooling circuit should fully evaluate the benefits and compare them with the cost of any additional equipment and the safety of the furnace and operators. If a system is implemented, the installation must incorporate fail-safe devices to protect the furnace.

10.2 Drying Raw Materials

In some circumstances waste heat in the furnace cooling water can be utilised to dry raw materials in the furnace stockyard. Where metallic charge materials are being added to a molten heel in an induction furnace, the presence of water in the scrap is potentially dangerous. Although scrap may be stored under cover at the foundry, it may be wet when delivered by the scrap dealer. The heat in the furnace cooling water can be extracted in an air-water heat exchanger and a fan used to convey the warmed air to the bases of stockyard bunkers.

11. SAFETY CONSIDERATIONS

Any process or operation associated with molten metal is potentially hazardous; adequate consideration should be given to minimising the risks.

Some hazards and the appropriate safeguards are common to all melting departments, irrespective of the melting plant involved, while others are peculiar to particular types of furnace equipment. More information on safety considerations is given in Appendix 2.

APPENDIX 1

PRINCIPLES OF ELECTRICAL INDUCTION MELTING

A1.1 Furnace Design

Most coreless induction furnaces consist of a robust steel shell that is mounted on trunnions and fitted with a mechanism for tilting, usually by hydraulic power; however, some furnace bodies are of open frame or concrete block construction. The trunnions are normally fitted at the front of the furnace body in line with the pouring lip.

A spiral, water-cooled electrical coil is mounted within the body shell. Furnace manufacturers have carefully designed and developed particular coils to provide the maximum operating efficiency and integrity for the applications specific to each furnace. The coil is subject to considerable electromechanical forces when the furnace is in operation. The methods of packing and mounting the coils have been systematically developed by the furnace manufacturers to overcome the problems associated with vibration and spurious magnetic fields. Layers of insulation may be applied to the coil and a crucible shape is formed, from refractory materials, within the centre. The metallic charge materials are placed inside the crucible and an alternating current is passed through the induction coil to provide the melting energy.

A coreless induction melting furnace normally comprises a cylindrical refractory, the top of which is open for charging and de-slagging operations. On all but the smallest furnaces, a refractory-lined swing lid is provided to reduce heat losses from the surface of the liquid metal; many units employ this facility to extract the fume and particulate generated.

Molten metal is transferred from an induction furnace into ladles, launders, etc., by tilting the furnace on its trunnions. The tilting mechanism is usually hydraulically powered, but on very small units tilting may be effected through geared hand wheels, hoist blocks, etc. In specialised situations, such as investment foundries, induction furnaces may be inverted completely to transfer metal. In other small-scale or specialised situations, the charge may be melted in a loose crucible which is removed from the induction coil and carried to the moulds for pouring.

A1.2 Power Supplies

Parallel and Series Inverters

Power supplies for medium frequency coreless furnaces consist of two basic designs:

- parallel inverters - the capacitor bank is in parallel with the furnace coil, the inverter being current fed (Fig 22);

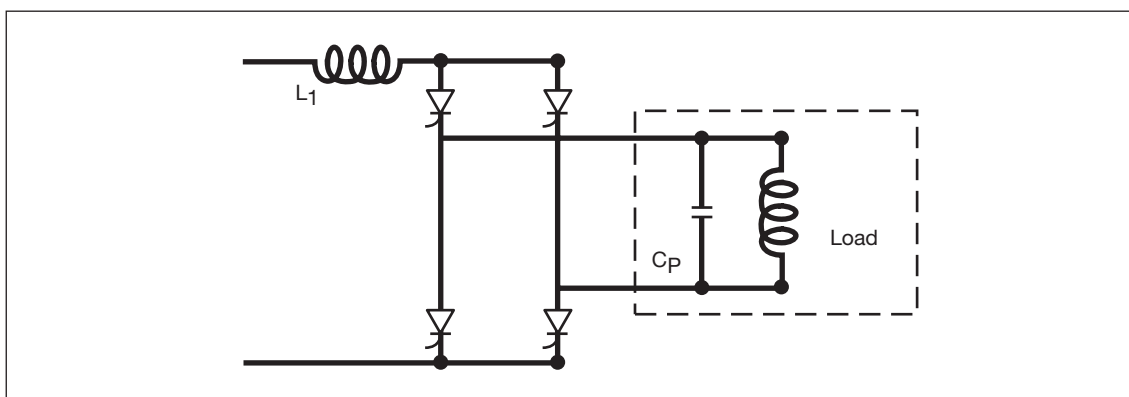

Fig 22 Circuit diagram of a parallel inverter

- series inverters - the capacitor bank is in series with the furnace coil, the inverter being voltage fed (Fig 23).

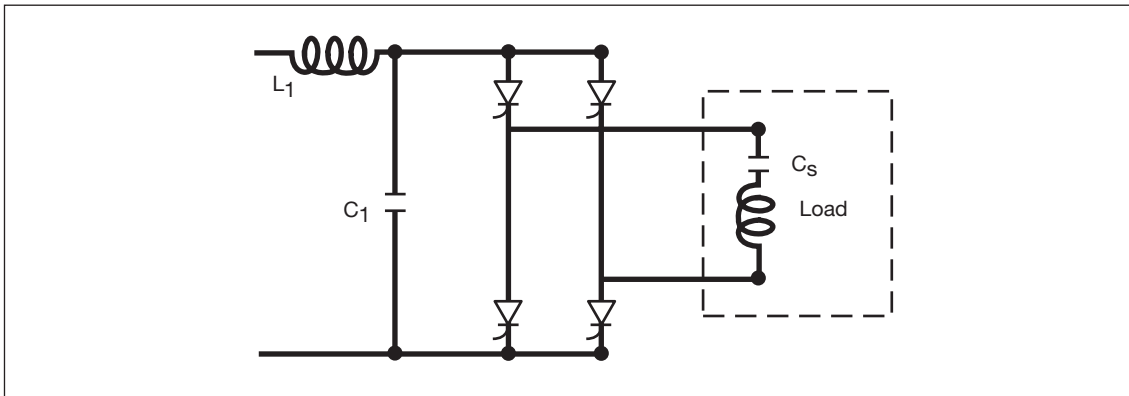

Fig 23 Circuit diagram of a series inverter

The size of thyristors in solid-state inverters now permits more powerful melting systems to be built without the need for multiple thyristor arrangements. Single thyristor bridges with power ratings of 500 - 700 kW are available and several megawatts of power can be obtained by paralleling such devices. The reduced number of components resulting from these developments has led to improved reliability.

Transistorised Power Supplies

A recent development is the replacement of SCR thyristor devices with transistorised power supplies. This new generation of power supply can provide higher powered, higher frequency systems at the start of the melt, while retaining the stirring action of a lower powered, lower frequency system.

Other advantages include:

- the ability to survive repeated short circuits (coil or bus-bar arcing) without damage;
- increased frequency of operation resulting in less stress on capacitors and, therefore, increased reliability;
- increased efficiency (>98%).

A1.3 Penetration Depth of Induced Current

When an alternating current is passed through the induction coil of a melting furnace, a current of the same frequency is induced in the charge materials. The intensity of the induced current is highest at the exterior of the charge - about 86% of the total induced energy appears in the surface layer of the charge mass. The penetration depth of the induced current depends on the frequency of the alternating current; it is typically 8 cm at mains frequency (50 Hz) and 3 cm at 500 Hz.

APPENDIX 2

SAFETY

This appendix firstly outlines general safety hazards and precautions and then examines, in more detail, those associated with electrical induction furnaces. The information provided is general only - each foundry must consider safety based on site conditions and operations.

A.2.1 General Hazards and Precautions

Protection against Molten Metal

The Health and Safety at Work Act 1974 and other legislation require safety equipment to be provided for all employees exposed to the potential hazard of molten metal. This includes eye protection, foundry boots and gaiters, protective clothing and helmets. Wherever possible, fixed screens and refuges should also be used.

Stockyard and Material Reclamation

Safety in the stockyard is achieved principally by rigorous enforcement of good housekeeping. This involves safe and separate storage of materials, maintaining freedom of access, and employing sound handling and transportation techniques.

A.2.2 Hazards Associated with Induction Melting

1. **Charging wet materials and sealed scrap** - particularly where a molten heel practice is adopted - may create a serious hazard, possibly leading to violent explosions and the ejection of both solid and liquid material from the furnace. All raw materials should be stored under cover and only dry metallics charged.
2. **Bridging** occurs when a 'crust' forms over the pool of molten metal in the furnace. Under these circumstances rapid superheating of the molten pool can occur, resulting in increased lining erosion and possible perforation of the furnace coil, creating an explosion hazard. Operators must remain vigilant at all times and power should never be increased in an attempt to remove bridged material.
3. **Condensation** may be present on apparently dry materials and tools (spoons, rakes, etc.) and their introduction into the melt, particularly at a later stage, may lead to metal spitting or splashing. Where pig iron is employed, it should be introduced at an early stage, if possible, and all tools should be pre-heated before use.
4. **Metal breakout** through the furnace lining will put both plant and staff at risk. Lining integrity is, therefore, of vital importance. Most furnace plants include a metal dump pit to cater for breakout. It should be of adequate capacity and free of extraneous material - particularly water. Use of the dump pit should be a last resort because it may lead to serious heat damage to the installation.
5. **Physical and thermal shock** may result from poor furnace operating practices. Most refractory materials, even when well-installed and commissioned, have relatively low tensile properties and are brittle. If bulky material is dropped into an empty furnace the lining may crack, while similar problems may result from the use of excessive heating and cooling rates. Cracks increase the likelihood of metal breakout.
6. **Excessive metal temperatures** will cause all refractory materials to soften and melt, and will increase the rate of lining attack significantly. Modern, high power medium frequency coreless furnaces may have very high superheating capabilities, possibly in excess of 50°C per minute; therefore, adequate control or supervision is necessary to avoid overheating.

7. **Water-cooled circuits** are present in all induction furnace coils. The proximity of this cooling water to the metal in the furnace creates two dangers:

- Any water leakage from the coil may penetrate the lining, with the consequent risk of an explosion.
- Cooling system failure will result in an increased lining temperature and the possibility of more rapid refractory attack.

Power should only be applied to the furnace if the cooling system is in operation - interlocks are usually fitted to ensure this. An appropriate emergency water supply should be available: this system should be activated **automatically** in the event of a cooling water failure.

8. **Trapping and falling hazards** should be reduced by fitting appropriate guarding around the furnace pit and platform. Hydraulic system controls should be of the 'stop and release' type and positioned for maximum observation of the potential danger zones. They should also be fail-safe and, in the event of a malfunction, uncontrolled descent of the furnace should not occur.

9. **Emissions** such as dust are produced from handling of charge materials; but a more serious potential hazard is the installation and removal of furnace linings, particularly silica-based coreless refractories. Operators involved in conventional furnace lining installation or removal must wear approved respiratory equipment. Where possible, mechanised lining installation and removal equipment, e.g. former vibrators and push-out or lift-out devices, should be used.

10. **Electrical hazards:** With time, the normal wear of coreless furnace linings (or where metal penetration and cracking of the refractory have taken place) may lead to the melt becoming 'live'. In most instances, coreless furnaces are fitted with an earth leakage protection device that will trip-out the power supply if current leaks to earth. If such a system is inoperative, the current leak may be through the operator and any metal tools being used. It is also possible for the furnace structure to become 'live' due to a short circuit between the coil and structure. This is usually due to bridging by loose metallic material and normally results in coil damage or power failure.

Where possible, the earth protection circuit should be checked before each melt. Equipment should never be operated following trip-out of power due to earth leakage problems unless the cause is established as an electrical fault that has been rectified. Where such an electrical fault has not been found, or if any doubt exists, the furnace lining should be knocked out.

The Government's Energy Efficiency Best Practice Programme provides impartial, authoritative information on energy efficiency techniques and technologies in industry, transport and buildings. This information is disseminated through publications, videos and software, together with seminars, workshops and other events. Publications within the Best Practice Programme are shown opposite.

Further information

For buildings-related topics please contact:
Enquiries Bureau

BRECSU

Building Research Establishment
Garston, Watford, WD2 7JR
Tel 01923 664258
Fax 01923 664787
E-mail brecsuenq@bre.co.uk

For industrial and transport topics please contact:
Energy Efficiency Enquiries Bureau

ETSU

Harwell, Didcot, Oxfordshire,
OX11 0RA
Fax 01235 433066
Helpline Tel 0800 585794
Helpline E-mail etbppenvhelp@aeat.co.uk

Energy Consumption Guides: compare energy use in specific processes, operations, plant and building types.

Good Practice: promotes proven energy efficient techniques through Guides and Case Studies.

New Practice: monitors first commercial applications of new energy efficiency measures.

Future Practice: reports on joint R & D ventures into new energy efficiency measures.

General Information: describes concepts and approaches yet to be fully established as good practice.

Fuel Efficiency Booklets: give detailed information on specific technologies and techniques.

Energy Efficiency in Buildings: helps new energy managers understand the use and costs of heating, lighting etc.